



HONDA

Honda Hybrid Emergency Guide



HYBRID



Introduction

Part 1: Information for All Honda Hybrids

Identifying a Honda Hybrid	4
Petrol Engine	5
Electric Motor	5
12-Volt Battery	5
Underhood Fuse Box	5
Positive Battery Terminal	5
High-Voltage Battery Modules	6
High-Voltage Battery Box	6
High-Voltage Cables	7

Potential Hazards

Flammable Fluids	8
Un-deployed Airbags and Seat Belt Tensioners	8
Electric Shock Potential	9
High-Voltage Battery Electrolyte	10
12-Volt Battery Electrolyte	10

Emergency Procedures

Vehicle Fire	11
Submerged or Partially Submerged Vehicle	11
Preventing Current Flow Through High-Voltage Cables	11
Best Method for Preventing High-Voltage Flow All Models	12
Second-Best Method for Preventing High-Voltage Flow	
<i>Except 2010-2013 Insight, CR-Z and 2012-2015 Jazz</i>	12
<i>2010-2012 Insight, CR-Z and 2012-2015 Jazz</i>	14
Extricating Occupants	15
Moving or Towing a Honda Hybrid	15

Part 2: Model-Specific Information

2000 - 2006 Honda Insight	16
2010 - 2013 Honda Insight	18
2003 - 2005 Honda Civic Hybrid	20
2006 - 2011 Honda Civic Hybrid	22
2012 - 2015 Honda Jazz Hybrid	24
2011 - 2013 Honda CR-Z	26

INTRODUCTION

This booklet has been prepared to help emergency services identify Honda petrol-electric hybrids and respond safely to incidents involving these vehicles.

Part 1 presents general information and recommendations that apply to all Honda hybrids produced through to the 2015 model year.

Part 2 contains model-specific information for each hybrid model: Insight, Civic Hybrid, CR-Z, and Jazz. This guide will be updated or replaced as Honda continues to introduce new hybrid vehicles.



INSIGHT



CIVIC HYBRID



CR-Z



JAZZ HYBRID



IDENTIFYING A HONDA HYBRID

The Insight can be identified by its aerodynamic shape and by the name Insight and a hybrid badge on the rear of the vehicle. The 2000-2006 models have rear bumper skirts, where as later models do not.

Except for a few minor differences in equipment, such as a roof antenna, there is very little difference in the exterior or interior appearance of the Civic hybrid compared to those of their petrol - powered counterparts.

The CR-Z is a two-door sports car. The CR-Z is regarded as the spiritual successor to the second generation Honda CR-X in both name and exterior design.

The Jazz Hybrid can be identified by the hybrid badge on the rear. 2012-2015 Jazz hybrid included revised headlamps, rear lamps, and a new front grill.



Orange cables under the bonnet or orange shielding bolted to the undercarriage of a Honda tell you the vehicle is a hybrid.

All Hybrids Except 2010-2013 Insight, CR-Z and 2012-2015 Jazz.



Engine Motor 12-Volt Battery Under-hood Fuse Box

2010-2013 Insight, CR-Z and 2012-2015 Jazz.

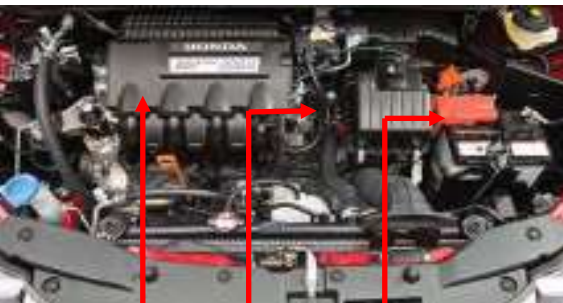

Engine Motor Positive Battery Terminal 12-Volt Battery

The easiest way to identify a hybrid is by the **HYBRID** badge on the rear of the vehicle. If the word hybrid is not visible on the rear of a vehicle due to damage for example, the presence of orange cables under the bonnet, or orange shielding under the car, would also identify the vehicle as a hybrid.

PETROL ENGINE

The main power source of all Honda hybrids is a conventional petrol engine, located under the bonnet.

ELECTRIC MOTOR

During start-up and acceleration, an electric motor, located between the engine and the transmission, provides assistance to the engine. During braking and deceleration, the motor acts as a generator, recharging both the high-voltage battery module and the 12-volt battery.

12-VOLT BATTERY

A conventional 12-volt battery, also located under the bonnet, powers all standard electronics. In Honda hybrids, this battery also provides power to the high - voltage battery control systems. Disconnecting or cutting the negative cable to the battery may be necessary in some emergency situations.

UNDER-HOOD FUSE BOX

All Honda hybrids except the 2010-2013 Insight, CR-Z and 2012-2015 Jazz have a fuse box under the bonnet on the driver's side of the engine compartment. Removing the main fuse from the box may be required in some emergency situations.

POSITIVE BATTERY TERMINAL

With 2010-2013 Insight, CR-Z and 2012-2015 Jazz the main fuse is located in the positive battery terminal. Cutting or removing the DC to DC converter cable, which is connected to this terminal, may be required in some emergency situations.



HV Battery Module

Single HV Battery "Stick"

Single HV Cell

D-Cell Battery



One of Four Battery "Stacks"



Other High-Voltage Components

High-Voltage Battery Module

HIGH VOLTAGE BATTERY MODULES

The electric motors in all Honda hybrid models before 2013 are powered by a nickel-metal-hydrate (NiMH) battery module. This type of battery contains groups, or "sticks," of 1.2-volt cells, each about the size of a D-cell battery. The number of cells varies by vehicle model, and total voltages range from 100-160 Volts.

The electric motor in the 2013 CR-Z hybrid is powered by a Lithium ion (Li-Ion) battery module. This battery contains four groups, or "stacks," of ten 3.6-volt cells, each a little larger than a typical mobile phone. The total voltage is 100 volts, very similar to the NiMH batteries that power other Honda hybrids.

Since both types of battery modules are recharged whenever a Honda hybrid vehicle decelerates, neither of them ever needs external charging.

HIGH VOLTAGE BATTERY BOX

Each high-voltage battery module is stored in a sturdy box, such as the one shown here with the lid removed. The box contains other important components which, together with the battery, make up the Intelligent Power Unit (IPU). All components inside the battery box are completely insulated and isolated from the vehicle body.

For maximum safety, the battery box is positioned in the rear of the vehicle where it is well-protected from potential damage in a collision.



High-Voltage Cable Connection to Motor



High-Voltage Cord to Civic AC Compressor



Electrical shield bolted to undercarriage



Thermal shield near hot exhaust



High-Voltage Cable Visible

Undercarriage Cover

High-Voltage Alert Symbols

HIGH VOLTAGE CABLES

Electrical energy flows between the high-voltage battery module and the motor through heavy-duty orange cables.

In the 2006 - 2011 Civic Hybrid, high-voltage cables also deliver current to the air conditioning (AC) compressor. This allows the AC to continue running when the vehicle is in the Auto Idle Stop mode. (Under certain conditions, Auto Idle Stop automatically turns the engine off when the car comes to a stop. E.g. at traffic lights)

Between the battery box and the engine compartment, the high-voltage cables are routed under the vehicle inside sturdy orange plastic protective shields. Where the cables lie close to the exhaust system, a metal thermal shield covers, but does not obscure, the orange high-voltage shield.

To improve aerodynamics and fuel efficiency, some sections of the high-voltage cables are located behind paneling. High-voltage alert symbols (⚠) may be stamped into the paneling to indicate the cable's path



Follow recommended procedure to avoid possible injury from a deploying airbag or inflator

Honda hybrids do not present any unusual hazards. The vehicles have performed well in standard crash tests, with no damage to high-voltage components in front, side, or rear impacts.

FLAMMABLE FLUIDS

Petrol-electric hybrids have the same potential fire and explosion hazards as conventional vehicles. (See model-specific pages for 'flammable fluid' capacities.)

UN-DEPLOYED AIRBAGS AND SEAT BELT TENSIONERS

All Honda hybrids have front airbags and front seat belt tensioners. All except the 2000 - 2006 Insight have side airbags in front, and side curtain airbags are standard in all later Civic, 2010-2013 Insight, CR-Z and 2012-2015 Jazz. These systems all use pyrotechnic devices with a deactivation time of 3 minutes.

As with other airbag-equipped vehicles, being struck by a deploying front or side airbag, or cutting into a de-activated inflator, can result in moderate to severe injuries. Injuries can also result from contact with a deploying side curtain airbag, or having a seat belt tensioner activate unexpectedly.

To reduce the risk of injury during the deactivation period, we recommend the following:

- Keep out of the path of an undeployed front airbag, and do not cut into the center of the steering wheel or dashboard where the front airbags are stored.
- Do not cut into the rear (C) pillar on CR-Z, 2006 ~ Civics, 2010-2013 Insight, and 2012-2015 Jazz as that is where side curtain inflators are stored.
- Be aware that extreme heat (320-356°F; 160-180°C) can cause unintended airbag inflation.

ELECTRIC SHOCK POTENTIAL

Unprotected contact with any electrically live high-voltage component can cause serious charged injury or death. However, **receiving an electric shock from a Honda hybrid is highly unlikely** due to the following:

- Contact with the battery module or other components inside the battery box can **ONLY** occur if the box is damaged and the contents are exposed, or the box is opened without following proper precautions.
- Contact with the electric motor can occur only after one or more components are removed.
- The high-voltage cables can be easily identified by their distinctive orange colour, and contact with them can be avoided.

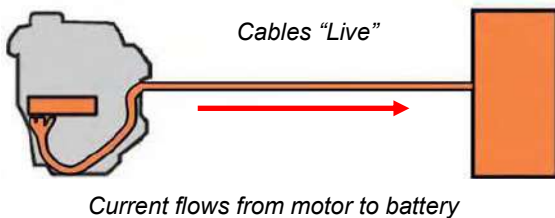
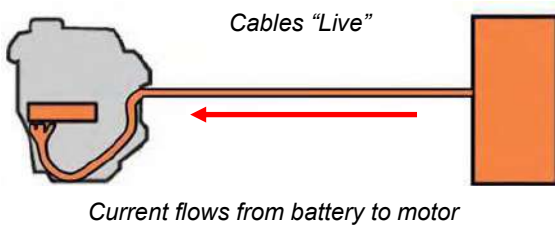

It's also important to understand in what situations the high-voltage cables can potentially be "live":

All Honda Hybrid models: Whenever the ignition switch is in the ON position and the engine is running, the high-voltage battery is either supplying current to the electric motor or receiving current generated by the electric motor.

Current flows from battery to AC Compressor

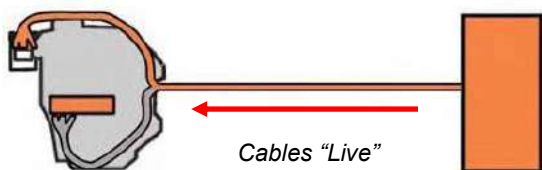

Ignition Switch is OFF

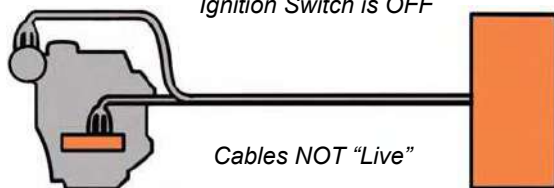

Electrolyte in the high-voltage battery cells is non-liquid and should not present a hazard

2006 Civic Hybrid: With this model, the high-voltage battery also powers the air conditioning compressor as well as the electric motor. So, if the ignition switch is in the ON position, the air conditioning is ON, and the engine has been turned OFF by the Auto Idle Stop feature (E.g. at traffic lights), then current will still flow through the cables to the air conditioning compressor.

In all Honda Hybrid models, if the ignition switch is turned OFF, the flow of high-voltage current will STOP.

Electric current cannot flow into the high-voltage cables when the ignition is OFF.

HIGH - VOLTAGE BATTERY ELECTROLYTE

Small quantities of a highly alkaline liquid electrolyte, which is corrosive to human tissue, are used in the manufacture of the NiMH high-voltage battery cells in all Honda hybrids except the 2013 CR-Z. However, in the finished cells, electrolyte is non-liquid and sealed in a sturdy case, and any leakage would be rare. The electrolyte is also non-flammable, non-explosive, and it creates no hazardous fumes or vapors in normal operating conditions, or in a fire.

The electrolyte in the Li-Ion battery module in the 2013 CR-Z Hybrid is flammable and will burn if the battery box is broken open, giving off gases that can cause irritation if inhaled. If the electrolyte simply leaks out, appropriate skin and eye protection are recommended.

12 - VOLT BATTERY ELECTROLYTE

Any hazards from contact with the 12-Volt battery electrolyte are the same as those with batteries in conventional passenger vehicles.

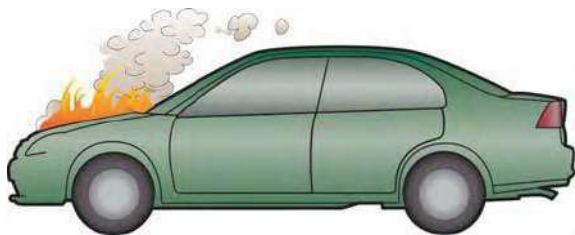

Standard procedures are recommended if a Honda hybrid is involved in a fire. Emergency services should also be aware of procedures for vehicles with an Li-Ion battery box.

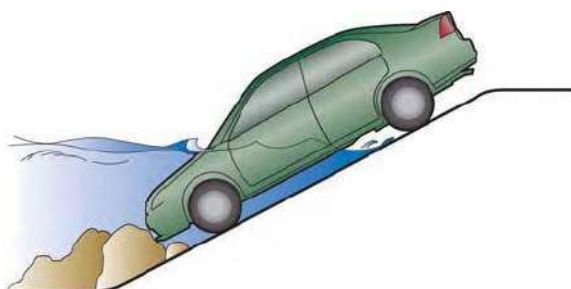

Pull vehicle from water, then follow recommended procedures for preventing high-voltage current flow.

Based on discussions with emergency services, we recommend that emergency response personnel follow standard procedures developed by their own organization for assessing situations and dealing with potential hazards. Given our knowledge of Honda hybrids, we also recommend that you use the procedures outlined in this section.

VEHICLE FIRE

There are no unusual hazards if a Honda hybrid is involved in a fire. If the 2013 CR-Z's Li-Ion battery box is engulfed in flames, or temperatures reach above 130°C (266°F), a pressure relief valve will open and release pressure, so the battery should not explode. However, the contents will burn, giving off gases that can cause irritation if inhaled. To extinguish a burning battery, the manufacturer recommends CO₂ or an abundance of water.

SUBMERGED OR PARTIALLY SUBMERGED VEHICLE

Pull the vehicle out of the water, then use one of the procedures described below for preventing electric current from flowing through the high-voltage cables. **There is no risk of electric shock from touching the car's body or framework - in or out of the water.**

PREVENTING CURRENT FLOW THROUGH HIGH - VOLTAGE CABLES

Before attempting to rescue occupants or move a damaged Honda hybrid, you should reduce the potential for current to flow from the electric motor or the battery module through the high-voltage cables.

There are **two recommended methods** for preventing current flow. These are discussed on the following pages.



Turning the ignition key to the OFF position stops the flow of electricity in the cables.

BEST METHOD FOR PREVENTING HIGH - VOLTAGE CURRENT FLOW (ALL MODELS)

TURN THE IGNITION SWITCH OFF

This simple action turns off the engine and the electric motor and cuts power to the high-voltage system controllers, thereby preventing current flow into the cables. It also turns off power to the airbags and the seat belt tensioners.

After you turn the ignition switch off, remove the key so the car cannot be accidentally restarted.

SECOND BEST METHOD FOR PREVENTING HIGH - VOLTAGE CURRENT FLOW (ALL MODELS EXCEPT 2010-2013 INSIGHT, CR-Z AND 2012-2015 JAZZ)

CUT BOTH NEGATIVE 12 - VOLT BATTERY CABLES AND REMOVE MAIN FUSE

Together, cutting the negative 12-volt battery cables and removing the main fuse turns off the engine and the electric motor and cuts power to the high-voltage system controllers, thereby preventing current flow into the cables. It also cuts power to the airbags and the seat belt tensioners.



Negative
Cables

1. Locate the 12-volt battery and cut the negative cables with diagonal cutters.



Main Fuse

Fuse Box
Cover

2. Locate the under hood fuse box and remove the cover. (see model specific pages for fuse box locations)

3. Locate the main fuse by referring to the diagram on top of, or inside, the fuse box cover. (The 2000-2006 Insight fuse box is shown here only as an example. See the model-specific pages for photos of the other models.)



Main Fuse
Screws

4. Using a Phillips screwdriver, unscrew the main fuse assembly and remove it from the box. (The 2003-2005 Civic Hybrid main fuse screws are shown here as an example. See the model specific pages for the locations for the other models.)

NOTE: If you cannot perform either method to stop the engine and prevent current flow into the high-voltage cables, use extreme care, do not cut into the cables, and do not touch damaged cables as they may be “live.”

SECOND BEST METHOD FOR PREVENTING HIGH - VOLTAGE CURRENT FLOW (2010 - 2013 INSIGHT, CR-Z AND 2012-2015 JAZZ)

CUT THE NEGATIVE 12 - VOLT BATTERY CABLE, THEN CUT OR DISCONNECT THE DC TO DC CONVERTER CABLE AT THE POSITIVE BATTERY TERMINAL

Together, cutting the 12-volt negative cable and cutting or disconnecting the DC to DC converter cable turns off the engine and the electric motor and cuts power to the high - voltage system controllers. This stops the flow of current into the high-voltage cables and cuts power to the airbags and the seat belt tensioners.

1. Locate the 12-volt battery and cut the negative battery cable.



12 - Volt
Battery

Negative
Battery
Cable



Positive Battery
Terminal

2. Locate the positive battery terminal and remove the cover.



*DC to DC Converter
Cable Connection*

3. Cut or disconnect the DC to DC converter cable

EXTRACTING OCCUPANTS

If cutters or spreaders are needed to allow occupants to be rescued, make sure to stay within the cut zones recommended on the following pages.

MOVING AND TOWING A HONDA HYBRID

If a disabled vehicle needs to be moved a short distance (to the side of the road, for example), and the car can still roll on the ground, the easiest way is to shift the transmission into neutral and manually push the vehicle.

To transport a vehicle away from an emergency location, a flatbed truck should be used if the vehicle might be repaired. If a flatbed is not available, the vehicle should be towed by wheel-lift equipment with the front wheels off the ground. Do not use sling-type towing equipment unless the car has been damaged beyond repair.

INSIGHT 2000 - 2006



2000-2006 Insight models are 2-passenger cars with a distinctive aerodynamic shape and rear fender skirts.

"Hybrid" Label



Depending on the model year, a hybrid badge will appear on the right or left rear of the vehicle.

KEY COMPONENTS

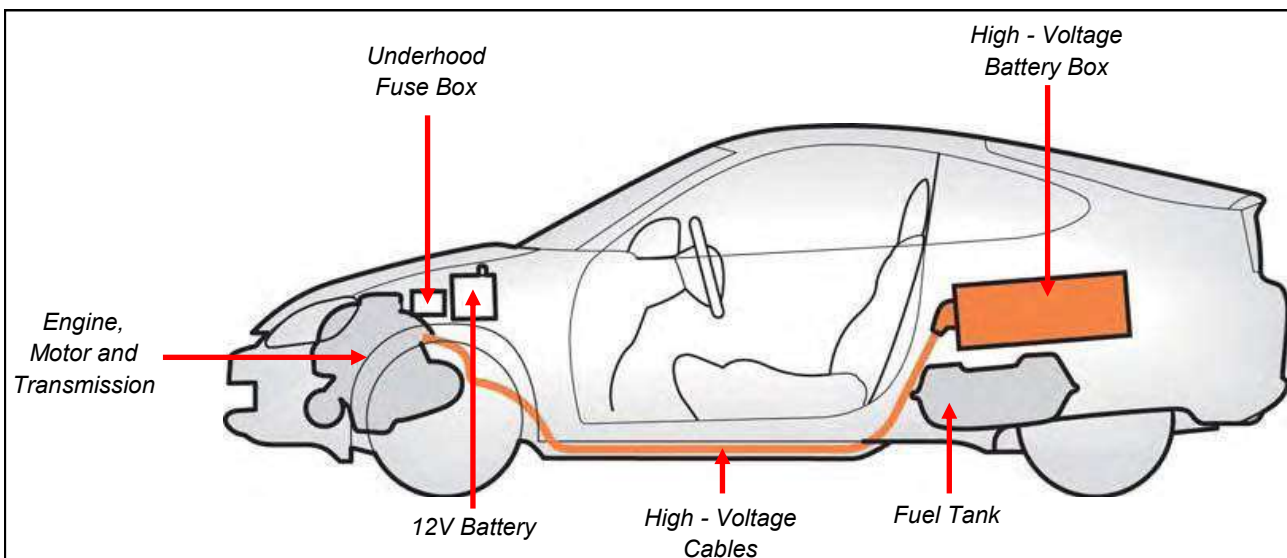
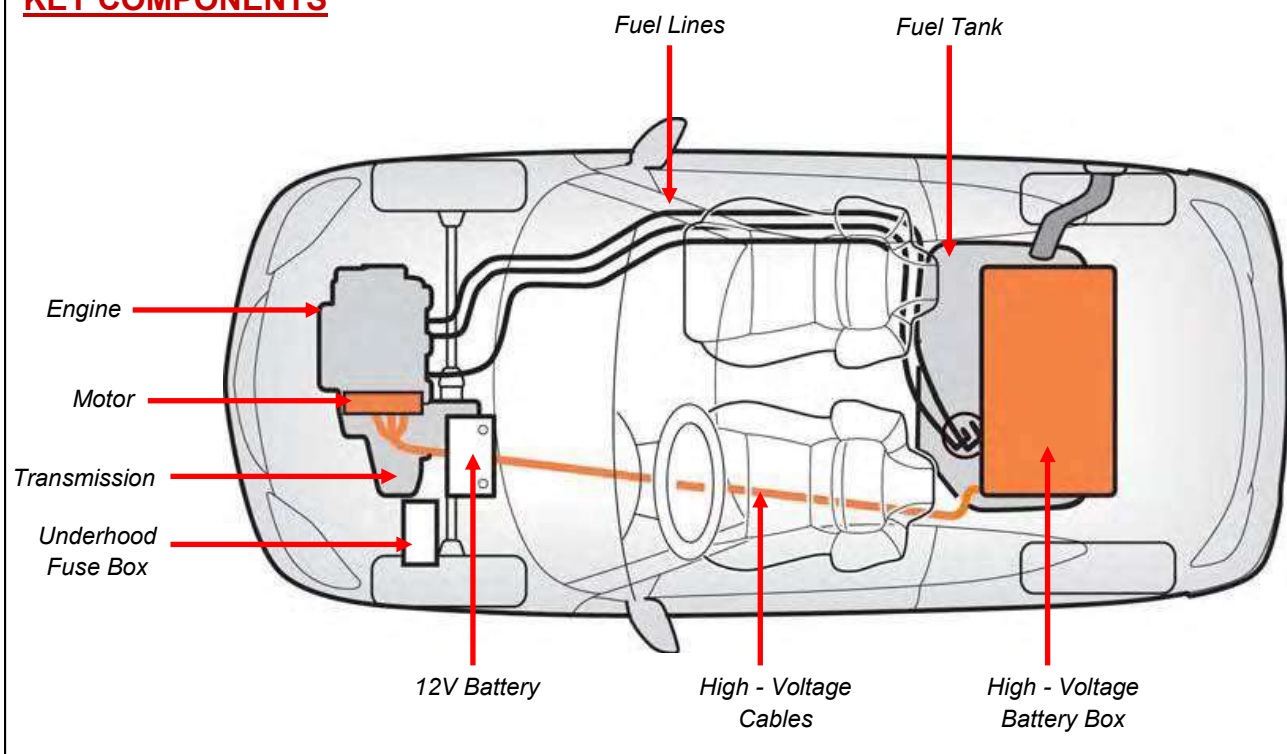

FLAMMABLE FLUIDS

Fuel Tank Capacity 40 litres

Engine Oil: 3.0 litres

Transmission Fluid:

CVT: 3.2 litres

Manual: 1.5 litres

AIRBAGS AND SEAT BELT TENSIONERS

Front Airbags: Driver and front passenger ONLY

Seat Belt Tensioners: Driver and front passenger ONLY

MAIN FUSE LOCATION

Main Fuse Screws



UNDERHOOD COMPONENTS

Engine

12V Battery

Underhood Fuse Box



Motor

CUT ZONE

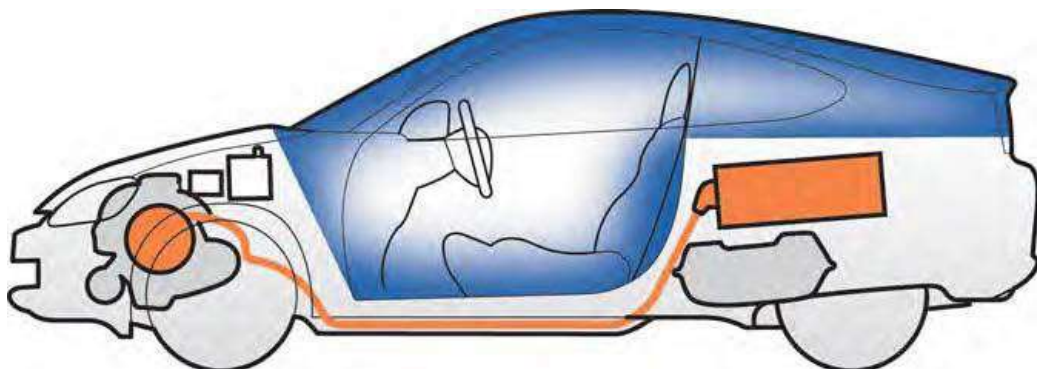

INSIGHT 2010 - 2013



The 2010 - 2013 Insight is a 5-door, 5-passenger vehicle.

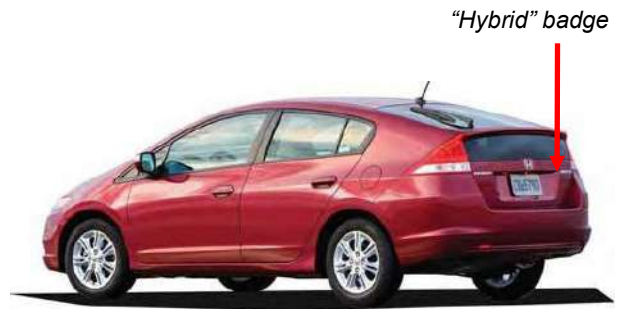

A hybrid badge appears on the right rear of the vehicle.

KEY COMPONENTS

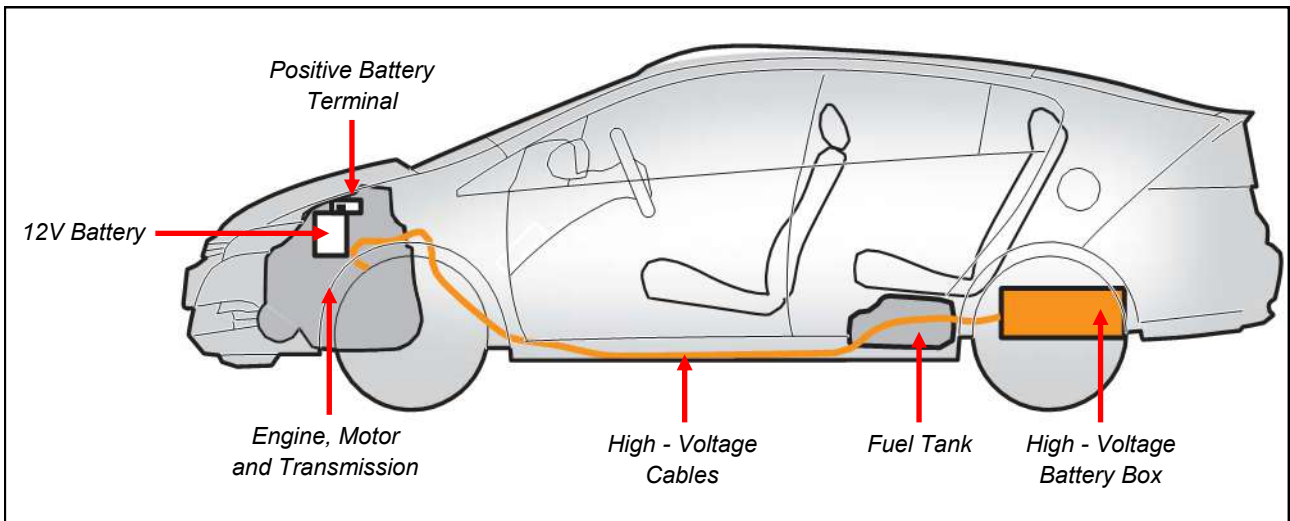
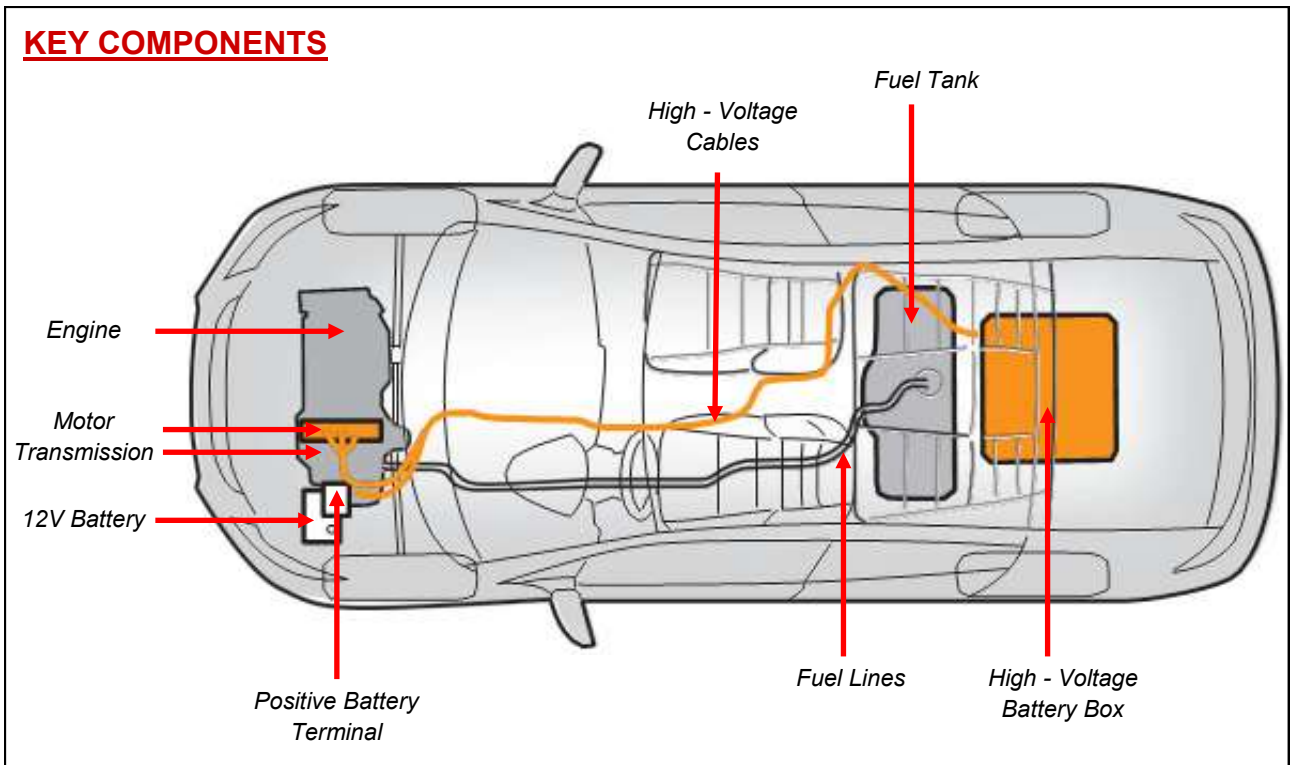

FLAMMABLE FLUIDS

Fuel Tank Capacity: 40 litres

Engine Oil: 3.6 litres

Transmission Fluid: 5.2 litres

AIRBAGS AND SEAT BELT TENSIONERS

Front Airbags: Driver and front passenger ONLY

Seat Belt Tensioners: Driver and front passenger ONLY

Side Airbags: Driver and front passenger ONLY

Side Curtain Airbags: Driver and front passenger and outer rear passengers

POSITIVE BATTERY TERMINAL

DC to DC Converter
Cable Connection



UNDERHOOD COMPONENTS

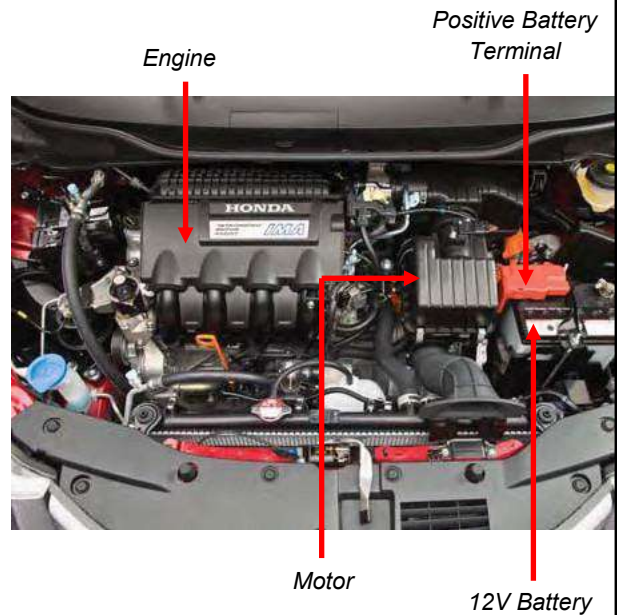

CUT ZONE

Side Curtain Airbag Inflators

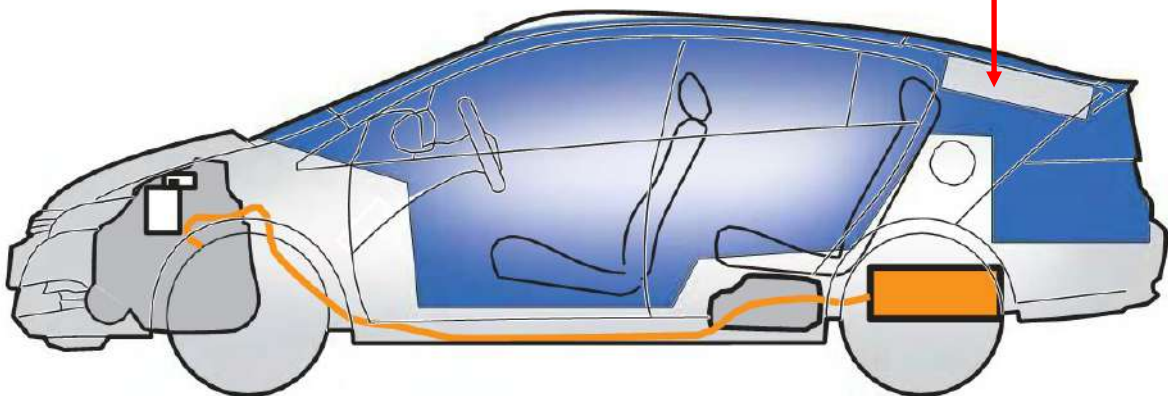

CIVIC HYBRID 2003 - 2005



The Civic Hybrid appears virtually the same as a conventional Civic.



"Hybrid" badge or label

Look for a Hybrid label or badge on the right or left rear at the level shown above.

KEY COMPONENTS

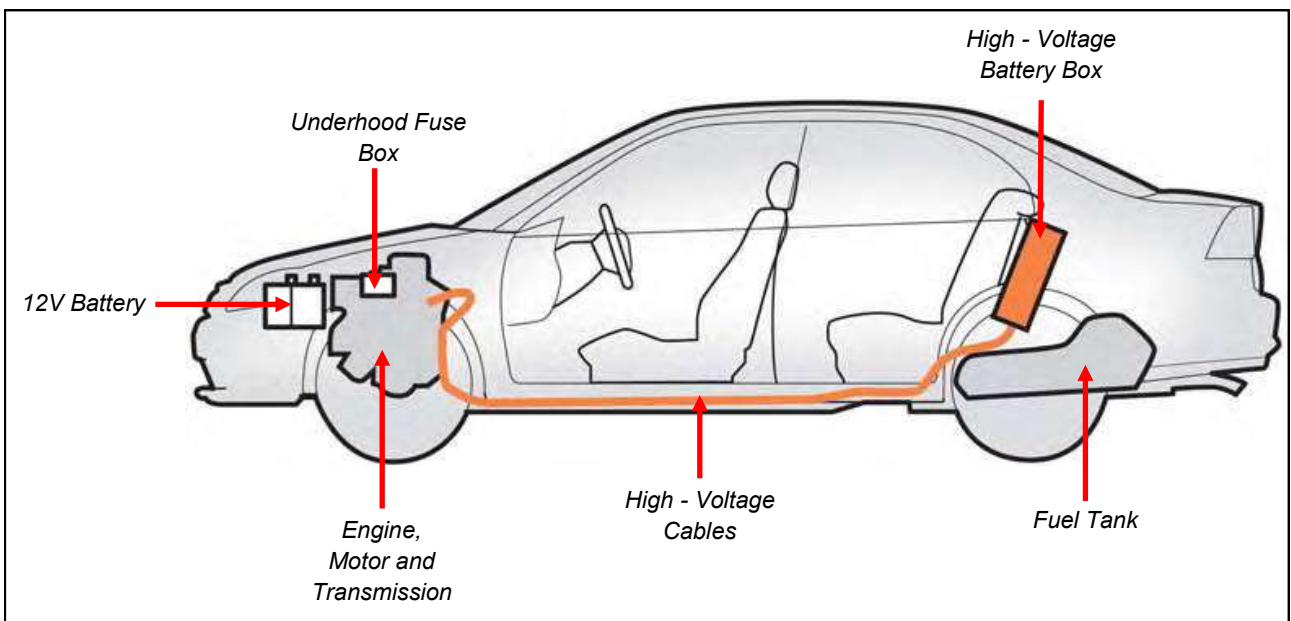
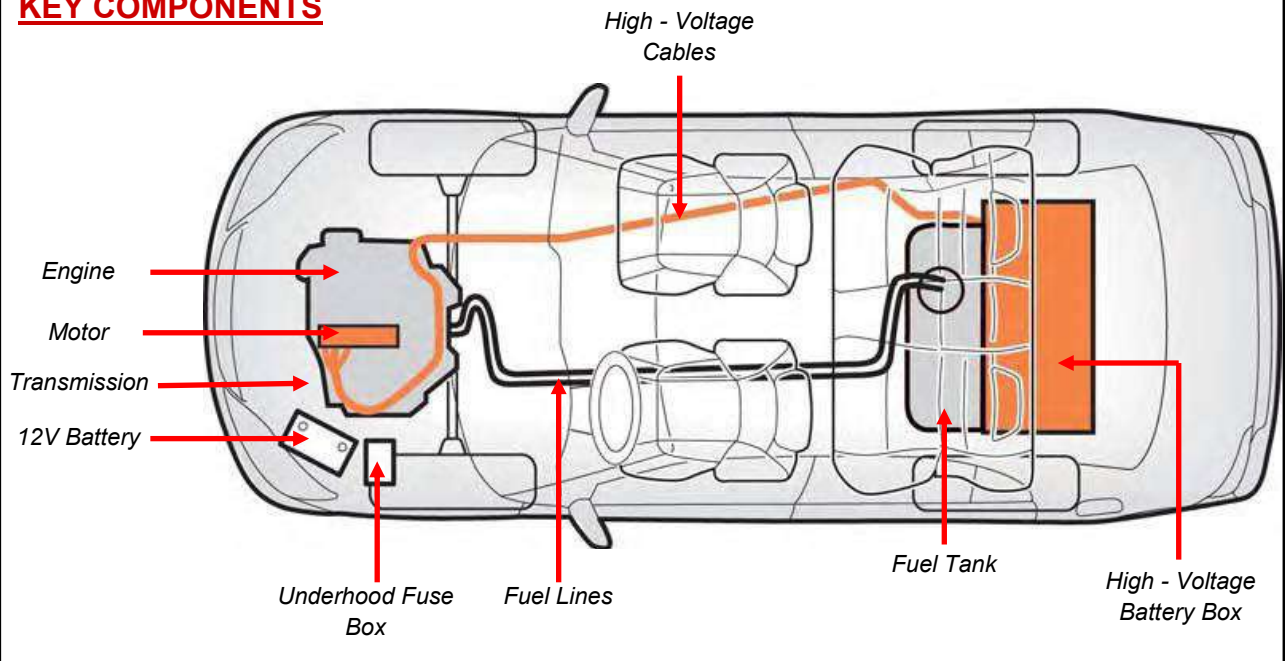

FLAMMABLE FLUIDS

Fuel Tank Capacity: 50 litres

Engine Oil: 3.0 litres

Transmission Fluid:

CVT: 3.2 litres

Manual: 1.5 litres

AIRBAGS AND SEAT BELT TENSIONERS

Front Airbags: Driver and front passenger ONLY

Seat Belt Tensioners: Driver and front passenger ONLY

Side Airbags: Driver and front passenger ONLY

UNDERHOOD COMPONENTS

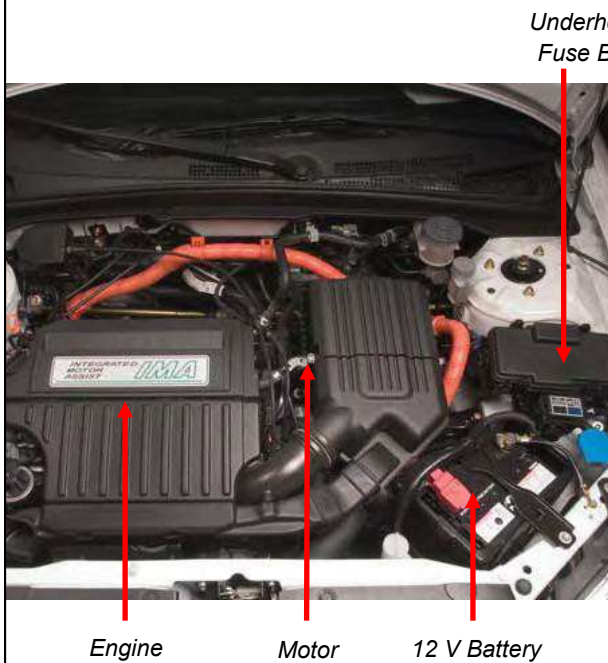

MAIN FUSE LOCATION



CUT ZONE

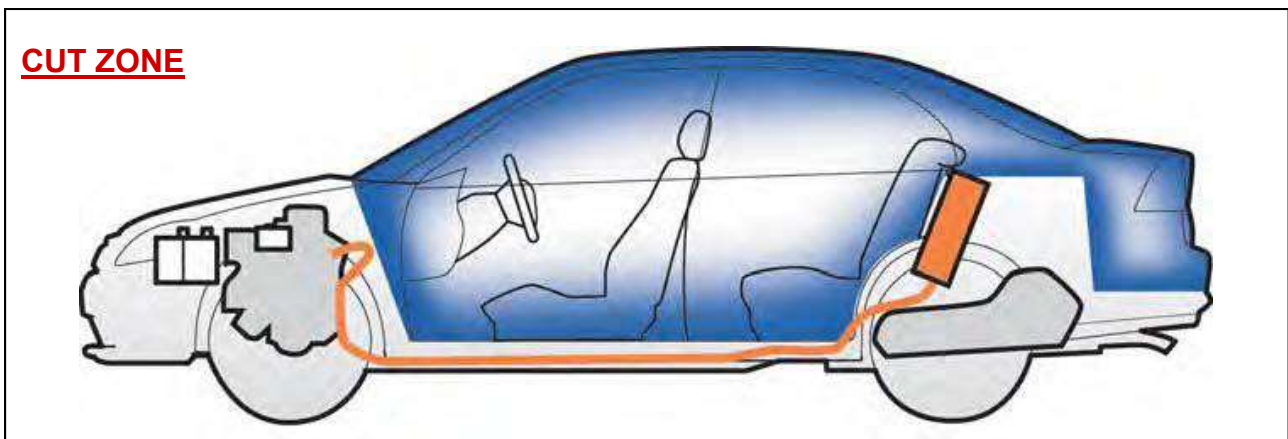

CIVIC HYBRID 2006 - 2011



The appearance of 2006-2011 Civic Hybrid is essentially the same as conventional 4-door Civic Saloon.



The word "Hybrid" appears on the right rear of these vehicles.

KEY COMPONENTS

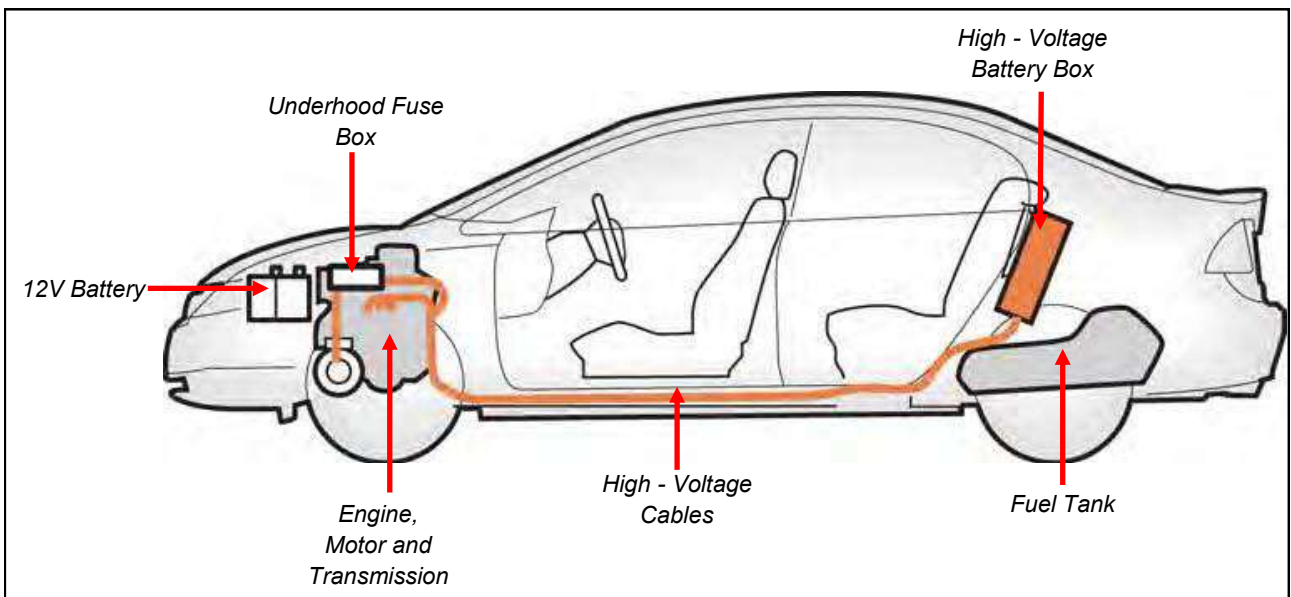
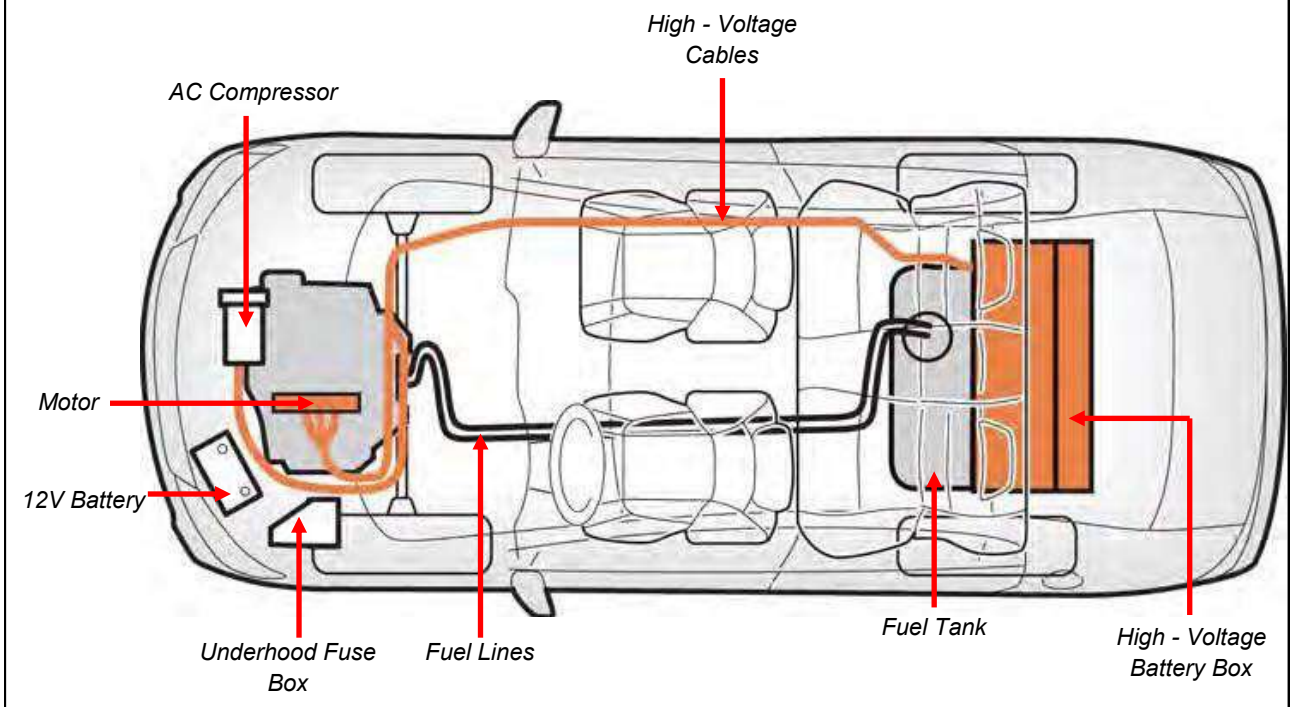

FLAMMABLE FLUIDS

Fuel Tank Capacity: 50 litres

Engine Oil: 3.8 litres

Transmission Fluid: 5.1 litres

AIRBAGS AND SEAT BELT TENSIONERS

Front Airbags: Driver and front passenger ONLY

Seat Belt Tensioners: Driver and front passenger ONLY

Side Airbags: Driver and front passenger ONLY

Side Curtain Airbags: Driver and front passenger and outer rear passengers

UNDERHOOD COMPONENTS



Engine

Motor

12V Battery

Underhood Fuse Box

MAIN FUSE LOCATION



Main Fuse Screws

CUT ZONE

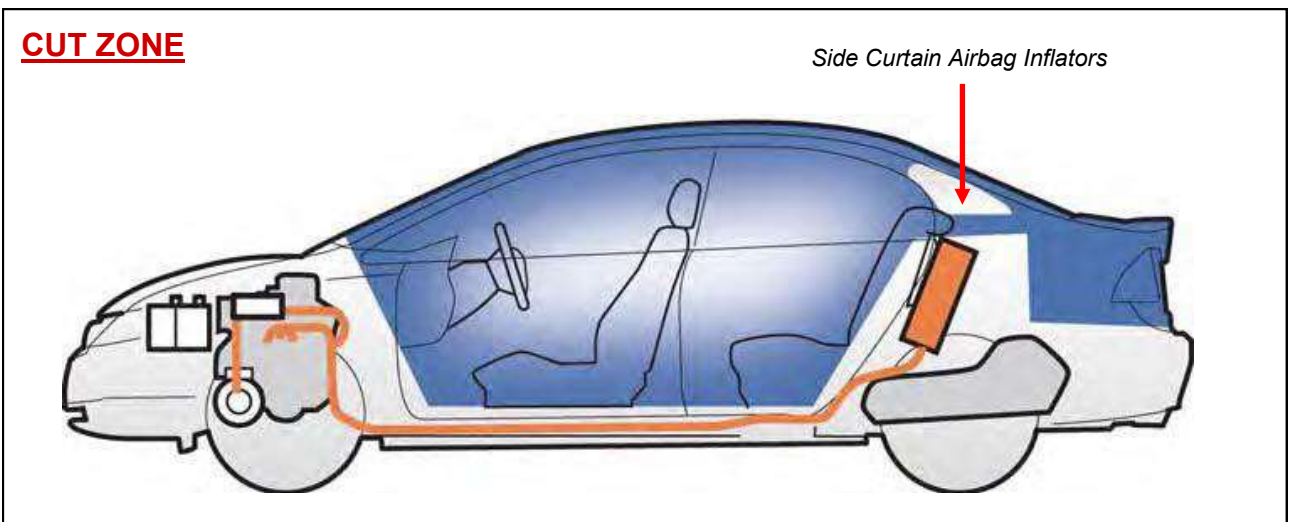

Side Curtain Airbag Inflators

JAZZ HYBRID 2012 - 2015



The 2012 Jazz Hybrid is a practical 5-door hatchback.

The Hybrid badge appears on the right rear of the vehicle.

KEY COMPONENTS

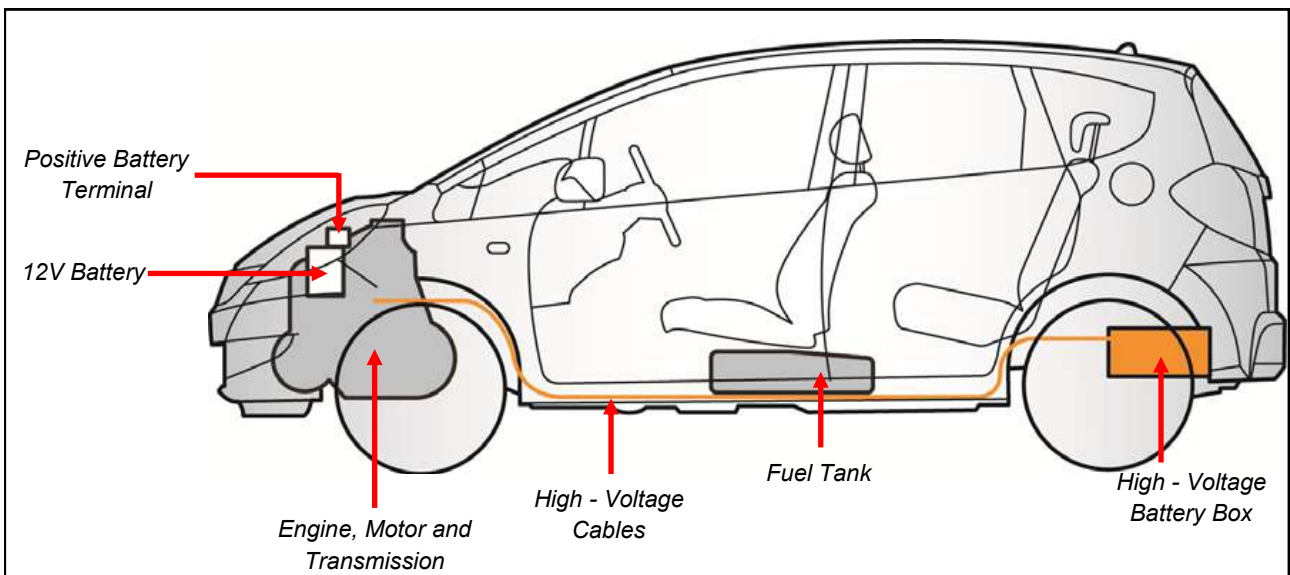
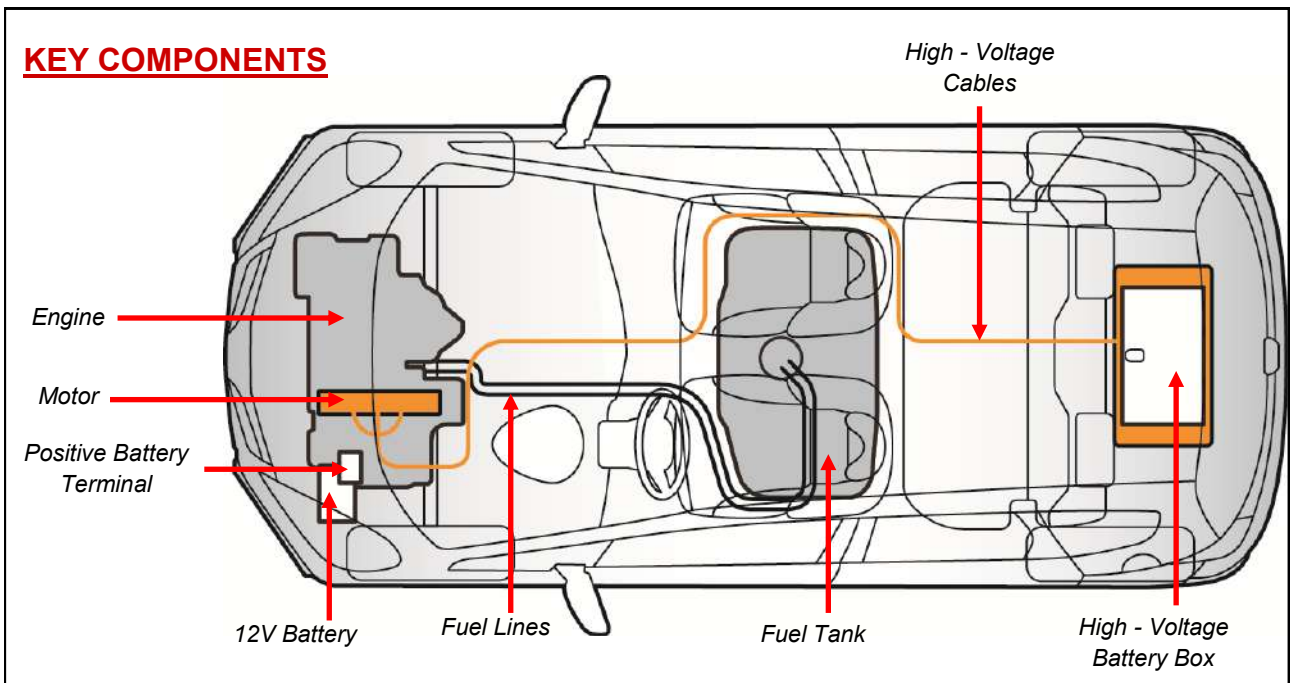

FLAMMABLE FLUIDS

Fuel Tank Capacity: 40 litres

Engine Oil: 3.6 litres

Transmission Fluid: 5.3 litres

AIRBAGS AND SEAT BELT TENSIONERS

Front Airbags: Driver and front passenger ONLY

Seat Belt Tensioners: Driver and front passenger ONLY

Side Airbags: Driver and front passenger ONLY

Side Curtain Airbags: Driver and front passenger
and outer rear passengers

UNDERHOOD COMPONENTS

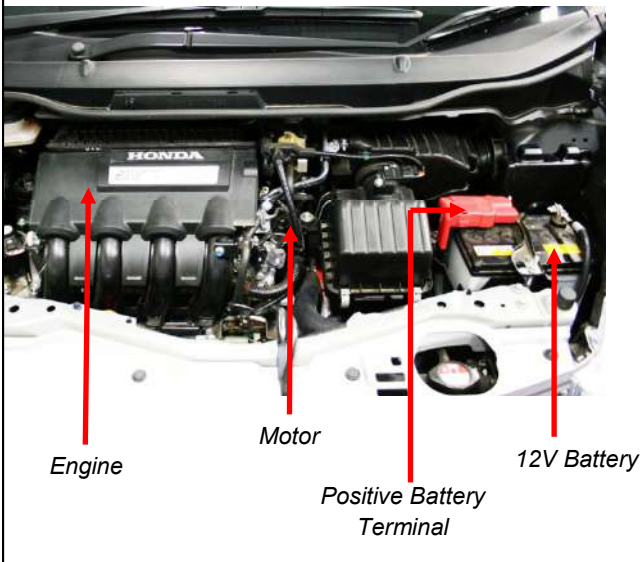

POSITIVE BATTERY TERMINAL

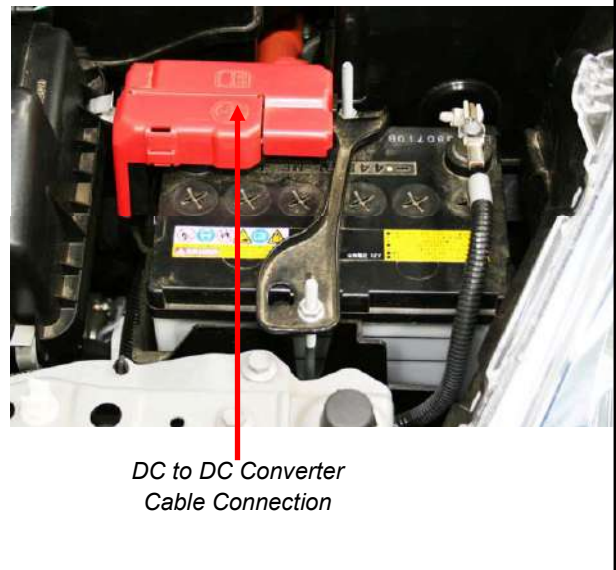

CUT ZONE

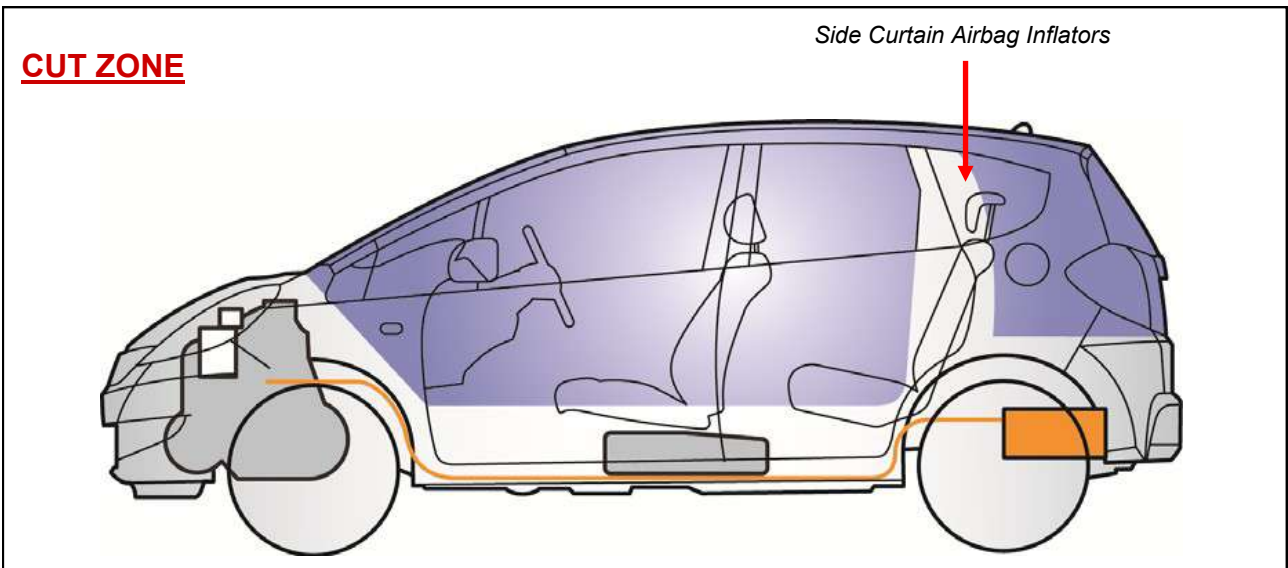

IDENTIFYING THE CR-Z 2011 - 2013



The 2011-2013 CR-Z is a 2-door sports car.



The Hybrid badge appears on the right rear of the vehicle.

KEY COMPONENTS

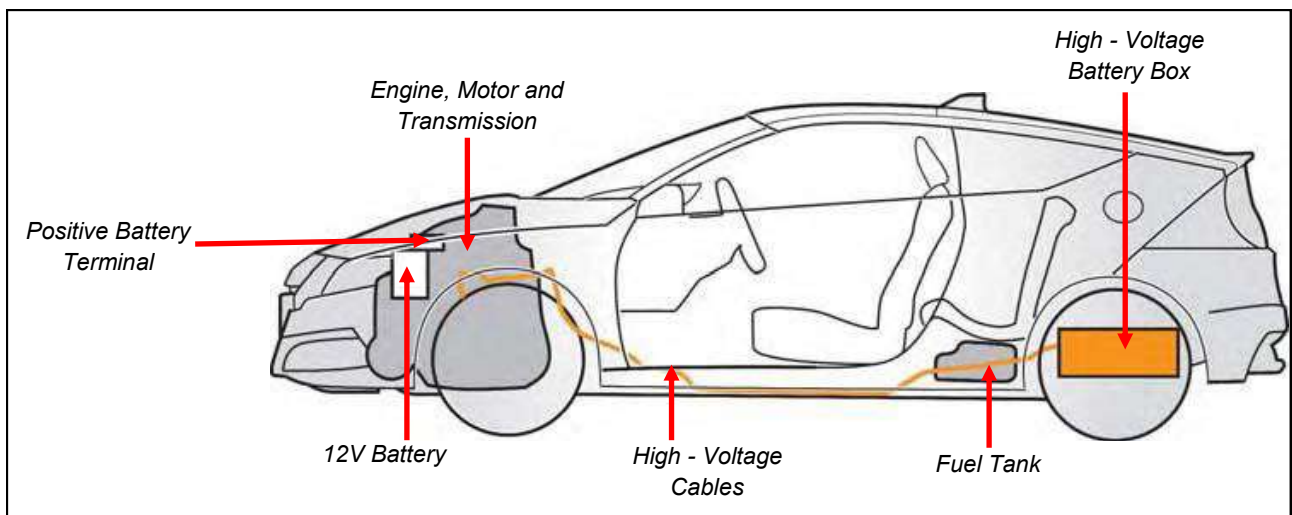
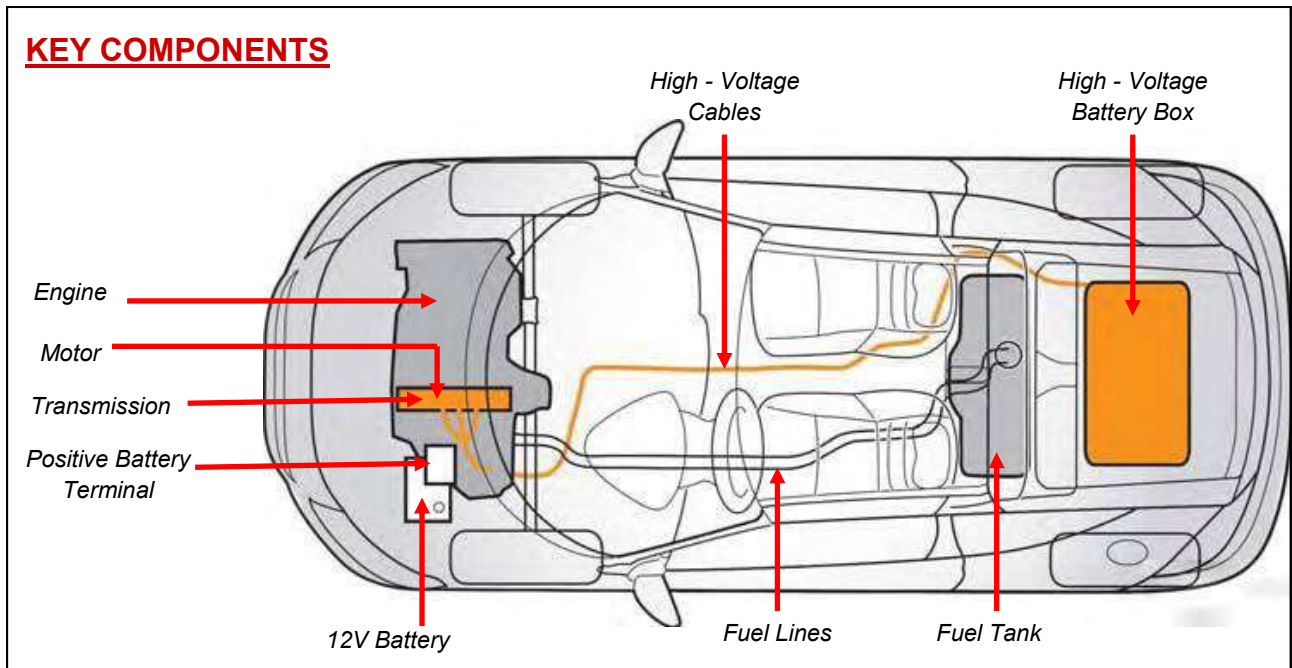

FLAMMABLE FLUIDS

Fuel Tank Capacity: 40 litres

Engine Oil: 3.6 litres

Manual: 1.4 litres

AIRBAGS AND SEAT BELT TENSIONERS

Front Airbags: Driver and front passenger ONLY

Seat Belt Tensioners: Driver and front passenger ONLY

Side Airbags: Driver and front passenger ONLY

Side Curtain Airbags: Driver and front passenger and rear outer passengers

UNDERHOOD COMPONENTS

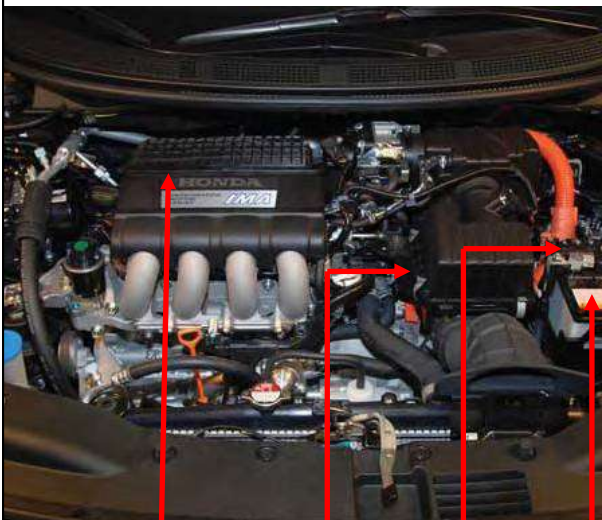

Engine

Motor

12V Battery

Positive Battery Terminal

POSITIVE BATTERY TERMINAL



DC to DC Converter Cable

CUT ZONE

