

Special Post Crash Safety Considerations

- Emergency responders should check a vehicle for markings or other indications that it is electric-powered. If it is, they should exercise caution, per published guidelines, to avoid any possible electrical shock and should disconnect the battery from the vehicle circuits if possible.
- Emergency responders should also use copious amounts of water if fire is present or suspected and, keeping in mind that fire can occur for a considerable period after a crash, should proceed accordingly.
- Operators of tow trucks and vehicle storage facilities should ensure the damaged vehicle is kept in an open area instead of inside a garage or other enclosed building.
- Rather than attempt to discharge a propulsion battery, an emergency responder, tow truck operator, or storage facility manager should contact experts at the vehicle's manufacturer on that subject.
- Vehicle owners should not store a severely damaged vehicle in a garage or near other vehicles.

transit /tourneo connect electric



EMERGENCY RESPONSE GUIDE

Introduction

The emergency response procedures for the Transit / Tourneo Connect Electric vehicles are similar to those for traditional gasoline or diesel-powered vehicles with the addition of special considerations for the high-voltage electric system components.

The vehicle uses a high voltage electric motor to power the vehicle. The energy used to power the vehicle comes from an on-board high voltage battery pack. There is no internal combustion engine or fuel tank.

The high-voltage system is charged by plugging the vehicle into the electrical grid to obtain either 110V or 220-240V AC current.

The information in this guide will allow response to emergencies involving these vehicles to be as safe as with conventional vehicles.

These vehicles have been designed with many safety features for your protection.

These features help provide safe access to the vehicle under various conditions. However, when approaching a high-voltage vehicle in a fire, rescue or recovery situation, always follow one industry standard rule:

**ALWAYS ASSUME THE VEHICLE'S
HIGH-VOLTAGE SYSTEM IS POWERED UP !**

Electric Vehicle Identification

A unique badge is installed on the right, rear door to distinguish the Transit Connect Electric from the non-electric models.



Identification can also be quickly made with reference to the additional items on this and following pages.



Under the hood there are high voltage components instead of an internal combustion engine.

Electric Vehicle Identification



Orange cabling is found under the hood and underneath the vehicle to identify those wires carrying high voltage.



On the Right side of the vehicle – in the area normally occupied by the fuel cap – is the charge port.

Electric Vehicle Identification



The instrument cluster in the dash has unique markings.

A Vehicle Range Meter is found on the left side – in place of the tachometer. This indicates approximate vehicle range remaining from the high voltage charge.

A Vehicle State Of Charge Meter is to the left of and slightly above the speedometer and shows approximate charge. A battery icon is found here.

Electric Vehicle Identification

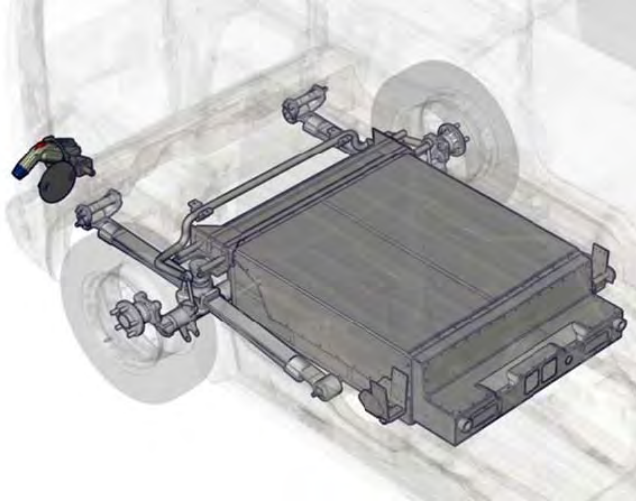

The sealed, liquid-cooled, high voltage battery pack is found under the vehicle – below the cargo area.

Mounted along the vehicle centerline, it fills the space forward of the rear wheels.

Orange cables run from the high voltage connections to the junction box mid-vehicle behind the front wheels.

Disconnecting High Voltage

The following list describes certain features that have been incorporated into the Transit / Tourneo Connect Electric vehicles that allow for either simple or automatic shutoff of the high-voltage electrical systems.

High-Voltage Fuse — In the event of a high-current short circuit, the high-voltage fuse will open, disabling the high-voltage system.

High-Voltage Interlock Circuit — Whenever a high-voltage connector is disconnected, the high-voltage interlock circuit opens and disables the high-voltage system.

Ignition Key in OFF Position — When the ignition lock cylinder is moved to the OFF position, the high-voltage system is disabled after a one-minute delay.

12V Battery Disconnected - Whenever the 12V battery is disconnected from the vehicle, the high voltage system is disabled.

High-Voltage Service Disconnect — Whenever the high-voltage service disconnect (located behind panels retained by screws at the front of the high voltage battery pack) is removed, the high-voltage system is disabled.

Thermal Sensors — In the event that the high-voltage battery temperature exceeds a given temperature limit, thermal sensors located inside the high voltage battery pack disable the high-voltage battery system.

Inertia Switch – In the event of a collision or severe jarring of the vehicle, an inertia switch – located behind the passenger (right) side kick panel – opens and disables the high voltage battery system.

High Voltage Labels



High Voltage Components

COMPONENT	LOCATION/DESCRIPTION	FUNCTION
Charge Port	Right side of vehicle behind the fuel filler door.	Provides connection point to external power for activation of on-board battery charging system.
High Voltage Battery Pack (290-384V)	Underneath cargo area along centerline of vehicle.	Provides high voltage for all system requirements.
High Voltage Junction Box	Mid-vehicle behind the front wheels.	Provides connections and fusing for cabling to high voltage components. High voltage orange cabling connections to DMoC, DC/DC Converter, HV Charger, AC Compressor, and cabin heater.
HV Charger	Behind traction motor under hood.	Converts 110V/220V AC voltage to 384V DC to charge high voltage battery.
Motor Controller (DMoC)	On top of traction motor under hood.	Translates signals from Control Unit and converts high voltage battery pack DC to 3-phase AC outputs to traction motor.
Traction Motor	Under hood coupled to the gearbox.	Provides power to move the vehicle and serves as generator for regenerative braking.
AC Compressor	Front right of traction motor.	HV electric motor driven compressor
Vacuum Pump	Back left of traction motor.	Provides vacuum for operation of power brake booster.
DC/DC Converter	Left frame rail underhood.	Converts high voltage DC to low voltage DC for operation of 12V vehicle components.
Electro-Hydraulic Power Assist System	Behind inner fenderwell forward of left front wheel.	Provides high pressure hydraulic fluid flow for power steering rack.
Gearbox	Under hood – coupled to traction motor.	Provides gear reduction output from traction motor and method of differentiation of front drive wheel speed.
Vehicle Control Unit (VCU)	On left side under hood beside 12V battery.	Controls operation of and communications with all vehicle systems.

NOTE: All high voltage wires and harnesses are wrapped in orange-colored insulation or have orange banding identification.

High Voltage Components

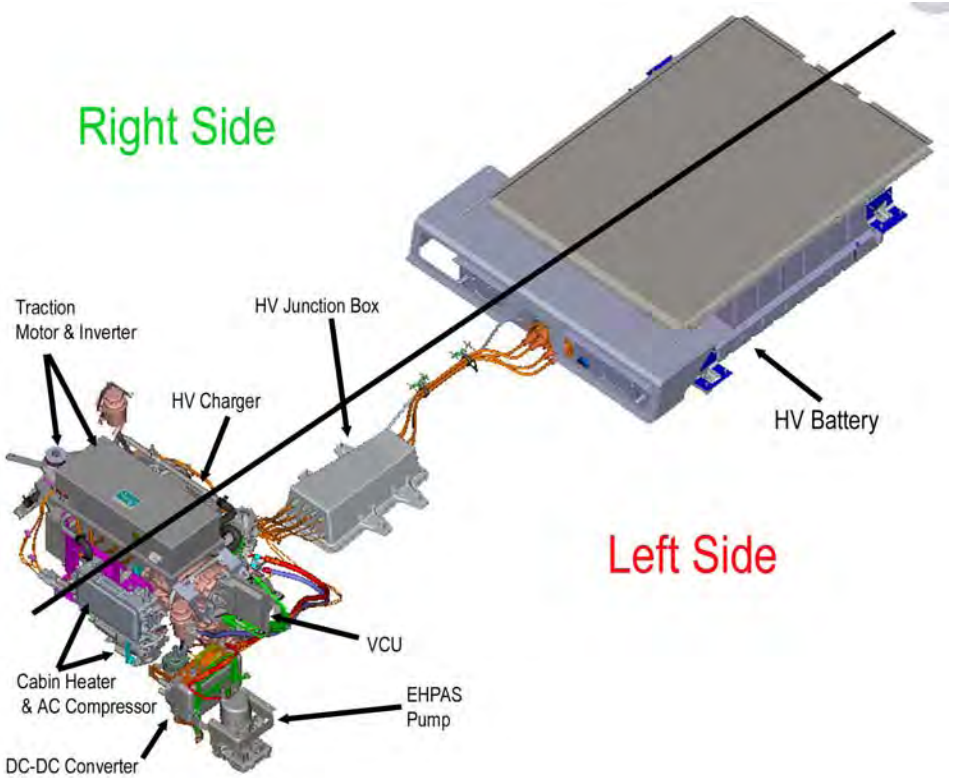

Note: All vehicle component location references refer to either Right or Left side as noted.

Vehicles may be RH or LH drive.

High Voltage Battery

WARNING

- Removing the high-voltage service disconnect will disconnect the high-voltage from the vehicle.
- The individual cells inside the battery pack will still be charged.
- Do not cut, weld or screw into the high-voltage battery case or penetrate the batteries in any way.

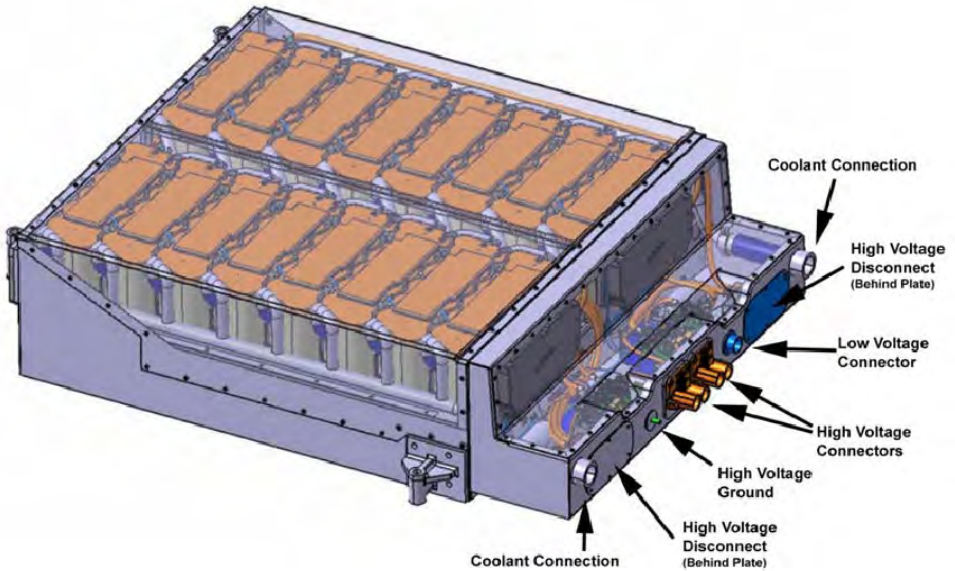

Potential Hazards / Public Safety

The high voltage battery pack consists of two strings of 8 battery modules in parallel.

Each module is comprised of 12 lithium ion, 4V batteries in series.

The total voltage of the battery pack is 384VDC when fully charged, 290VDC when discharged (345.0 VDC nominal).

The battery case is designed to be water resistant.

The high-voltage battery pack is located under the cargo area along the vehicle centerline.

High-Voltage Battery Contents

The lithium-ion battery is contained in a strong metal box and should present no hazard in normal circumstances.

However, the contents of the battery are flammable and can burn if the box is broken open, giving off gases that can cause irritation if inhaled. To extinguish a burning battery, the manufacturer recommends CO₂ or an abundance of water.

Potential Hazards / Public Safety

APPROACHING A DAMAGED HIGH-VOLTAGE VEHICLE

1. FOLLOW EXISTING TRAINING AND INCIDENT COMMANDER DIRECTION.

This guide provides only supplemental information as it pertains to the Transit / Tourneo Connect Electric vehicles.

The same rules apply when approaching any potential high-voltage situation. Always follow your high-voltage safety training. Some precautions to be taken in any high-voltage situation include:

- Remove all jewelry (watches, necklaces and earrings). Metal objects are conductors of electricity.
- Wear the necessary PPEs (high-voltage rubber gloves, face shield, insulated boots, protective raincoat or apron).
- Bring the following equipment:
- Class ABC powder-type fire extinguisher

A non-conductive object – about 1.5 m (5 ft) long – used to safely push someone away from the vehicle if they accidentally come in contact with high-voltage.

2. APPROACHING A DAMAGED VEHICLE.

Disable the high-voltage electrical system using the following steps::

- Secure the vehicle — place the shift lever into the PARK position.
- Remove the key—if possible.
- Block the wheels if necessary.
- Remove the ignition key. Block the wheels,
- Removing the ignition key or turning the key to the OFF position will disconnect the high-voltage system after a one-minute delay.
- Disconnect the negative cable from the 12-volt battery – this will also disable the high-voltage system.

In an emergency where access to the inside of the vehicle is not readily available, disconnect the 12V battery under hood by using bolt cutters to cut both negative and positive cables.



Potential Hazards / Public Safety

SPECIAL NOTES

If the vehicle is on fire, use a Class ABC powder-type extinguisher to contain and smother the flames. If water is being used, large amounts of water will be required (e.g., from a fire hydrant) to extinguish the flames.

If the vehicle has any exposed cables, make sure to wear high-voltage rubber gloves and other protective clothing. Do not touch any broken or damaged high-voltage orange cables. Treat severed cables as if they contain high voltage.

If the vehicle is submerged in water, do not touch any high-voltage components or orange cables while extricating the occupant(s). Do not remove the vehicle until you are sure the high-voltage battery is completely discharged. A submerged high-voltage battery may produce a fizzing or bubbling reaction. The high-voltage battery will be discharged when the fizzing or bubbling has completely stopped.

3. IF THE HIGH-VOLTAGE BATTERY CASE HAS BEEN RUPTURED.

- Just like any other battery, hose the area down with large amounts of water.

4. MOVING DAMAGED VEHICLES — RECOVERY VEHICLE DRIVERS.

- Turn the vehicle ignition key to the ACCESSORY position to release the locking steering wheel, release the emergency brake, place gear selector in Neutral.
- If possible, remove the high-voltage service disconnect
- Follow the guidelines in the Wrecker Towing Manual.
- Tow from front or rear with wheel lift. **Slings are prohibited!**
- Flat bed: Front and Rear

5. SPECIAL NOTE TO SALVAGE YARDS.

- If a vehicle with a high-voltage battery is to be scrapped, the high-voltage battery must be disposed of following all local, state/provincial or federal guidelines.

Potential Hazards / Public Safety

FIRE OR EXPLOSION

- Lithium ion batteries contain flammable liquid electrolyte that may vent, ignite and produce sparks when subjected to high temperatures (> 150 °C (302 °F)), when damaged or abused (e.g., mechanical damage or electrical overcharging).
- May burn rapidly with flare-burning effect.
- May ignite other batteries in close proximity.

HEALTH

- Contact with battery electrolyte may be irritating to skin, eyes and mucous membranes.
- Fire will produce irritating, corrosive and/or toxic gases.
- Burning batteries may produce toxic hydrogen fluoride gas.
- Fumes may cause dizziness or suffocation.
- As an immediate precautionary measure, isolate spill or leak area for at least 25 meters (75 feet) in all directions.
- Keep unauthorized personnel away.
- Stay upwind.
- Keep out of low areas.
- Ventilate closed spaces before entering.

PROTECTIVE CLOTHING

- Wear positive pressure self-contained breathing apparatus (SCBA).
- Structural firefighters' protective clothing will only provide limited protection.

EVACUATION

- **Large Spill** -Consider initial downwind evacuation for at least 100 meters (330 feet).
- **Fire** - If rail car or trailer is involved in a fire, ISOLATE for 500 meters (1/3 mile) in all directions; also initiate evacuation including emergency responders for 500 meters (1/3 mile) in all directions.

Potential Hazards / Public Safety

FIRE

Small Fire

- Dry chemical, CO₂, water spray or regular foam.

Large Fire

- Water spray, fog or regular foam.
- Move containers from fire area if you can do it without risk.

SPILL OR LEAK

- ELIMINATE all ignition sources (no smoking, flares, sparks or flames in immediate area).
- Do not touch or walk through spilled material.
- Absorb with earth, sand or other non-combustible material.
- Leaking batteries and contaminated absorbent material should be placed in metal containers.

FIRST AID

- Move victim to fresh air.
- Call emergency medical service.
- Give artificial respiration if victim is not breathing.
- Administer oxygen if breathing is difficult.
- Remove and isolate contaminated clothing and shoes.
- In case of contact with electrolyte, immediately flush skin or eyes with running water for at least 20 minutes.
- Ensure that medical personnel are aware of the materials involved and take precautions to protect themselves.