

MDX Sport Hybrid

2017–20 Acura MDX Sport Hybrid Emergency Response Guide

Prepared for Fire Service, Law Enforcement, Emergency Medical, and Professional Towing Personnel

Supersedes 2017–19 Acura MDX Sport Hybrid Emergency Response Guide, dated September 2019

This guide has been prepared to assist emergency response professionals in identifying a 2017–20 MDX Sport Hybrid vehicle and safely respond to incidents involving this vehicle.

Copies of this guide and other emergency response guides are available for reference or downloading at <https://www.acura.ca/owners/esafety-info>.

For questions, please contact your local Acura dealer or Acura Client Relations at 1-888-946-6329.

Acura wishes to thank emergency response professionals for their concern and efforts in protecting Acura clients and the general public.



Contents

Vehicle Identification.....	4
Vehicle Dimensions.....	6
Vehicle Description.....	7
Component Location.....	10
Potential Hazards.....	13
Emergency Procedures.....	14
Emergency Procedures High-Voltage Shut Down Procedure.....	16-19
Emergency Procedures Extricating Occupants.....	19
Emergency Towing.....	20
Vehicle Repairs.....	21

You can identify an Acura MDX Sport Hybrid by the exterior **Hybrid** marks located on the front fenders and by the blue letters **SH** on the rear hatch. You can also identify an MDX Sport Hybrid by the orange cabling under the hood.



A 2017–20 Acura MDX Sport Hybrid can also be identified by inspecting the VIN at the three locations shown below.

Characters 4–6 of the VIN will show **YD7**, indicating that it is an Acura MDX SportHybrid.

5FR**YD7*******000001



In front of passenger seat under plastic panel marked **FRAME NUMBER**



In lower-right corner of windshield



On driver's door jamb

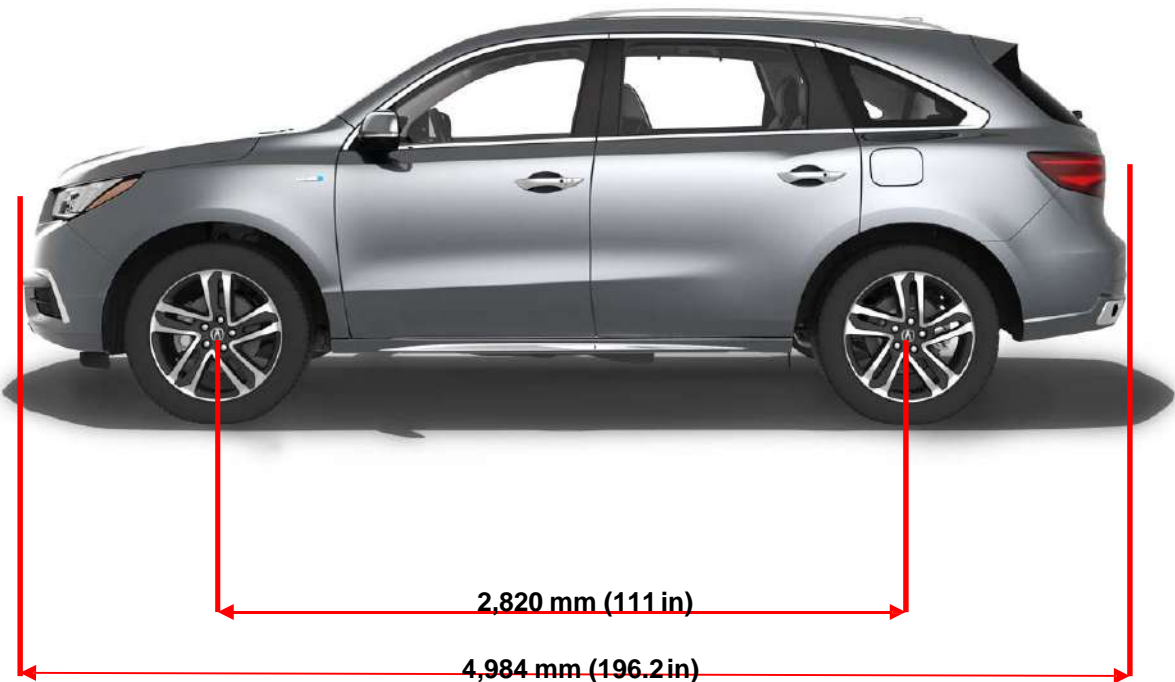

Vehicle Weight by Trim
Technology Package: 4,471 lb. (2,028 kg)
Advance Package: 4,486 lb. (2,034 kg)

High-Strength and Ultra-High-Strength Steel

The body of the Acura MDX Sport Hybrid is comprised of high-strength steel and ultra-high-strength steel as shown below.

Upper View

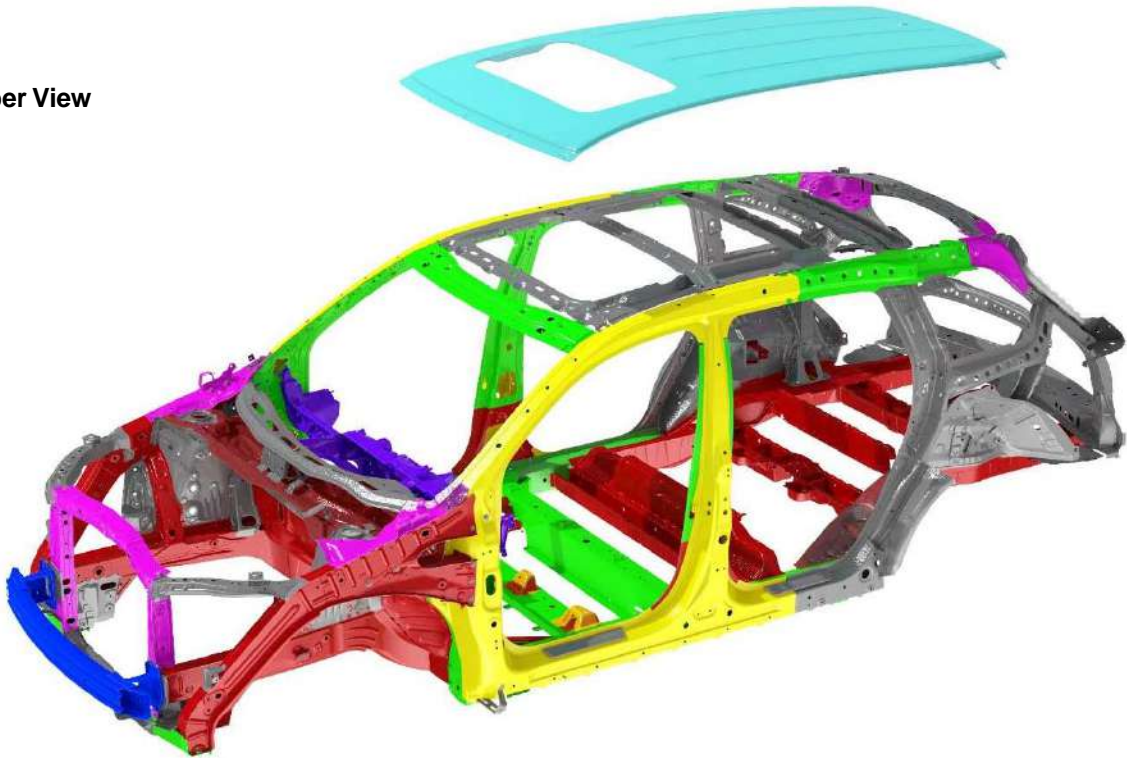

Lower View

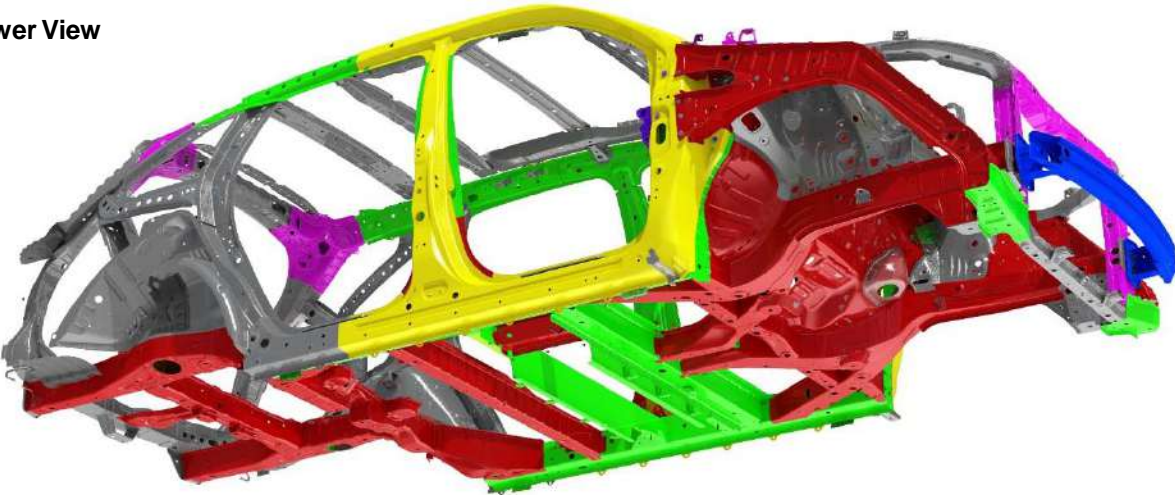

HSS 340	HSS 440	HSS 590	HSS 980	HSS 1500
Mild steel	MG	AL		

Seatbelts and Airbags

The Acura MDX Sport Hybrid is equipped with lap/shoulder belts in all seating positions. Front seat belts are equipped with pyrotechnically activated tensioners that help tighten the seat belt in a crash.

In addition, the Acura MDX Sport Hybrid is equipped with the following airbags:

- Front Airbags - Driver/Front Passenger
- Side Airbags – Driver/Front Passenger
- Side Curtain Airbags – Driver’s Side/Passenger’s Side (Both Rows)
- Knee Airbag - Driver

In a collision severe enough to deploy one or more of the airbags, the Acura MDX Sport Hybrid electrical system is designed to automatically open the high-voltage electrical contactors. This disconnects the high-voltage battery from the other high-voltage components and stops the flow of electricity in the high-voltage cables.

Responders should always assume, however, that the HV system is powered on and take the appropriate action described later in this guide to power off the system.

It takes up to 3 minutes for the airbags and tensioners to power off after the 12-volt system has been turned off by following the emergency shutdown procedures provided later in this guide.

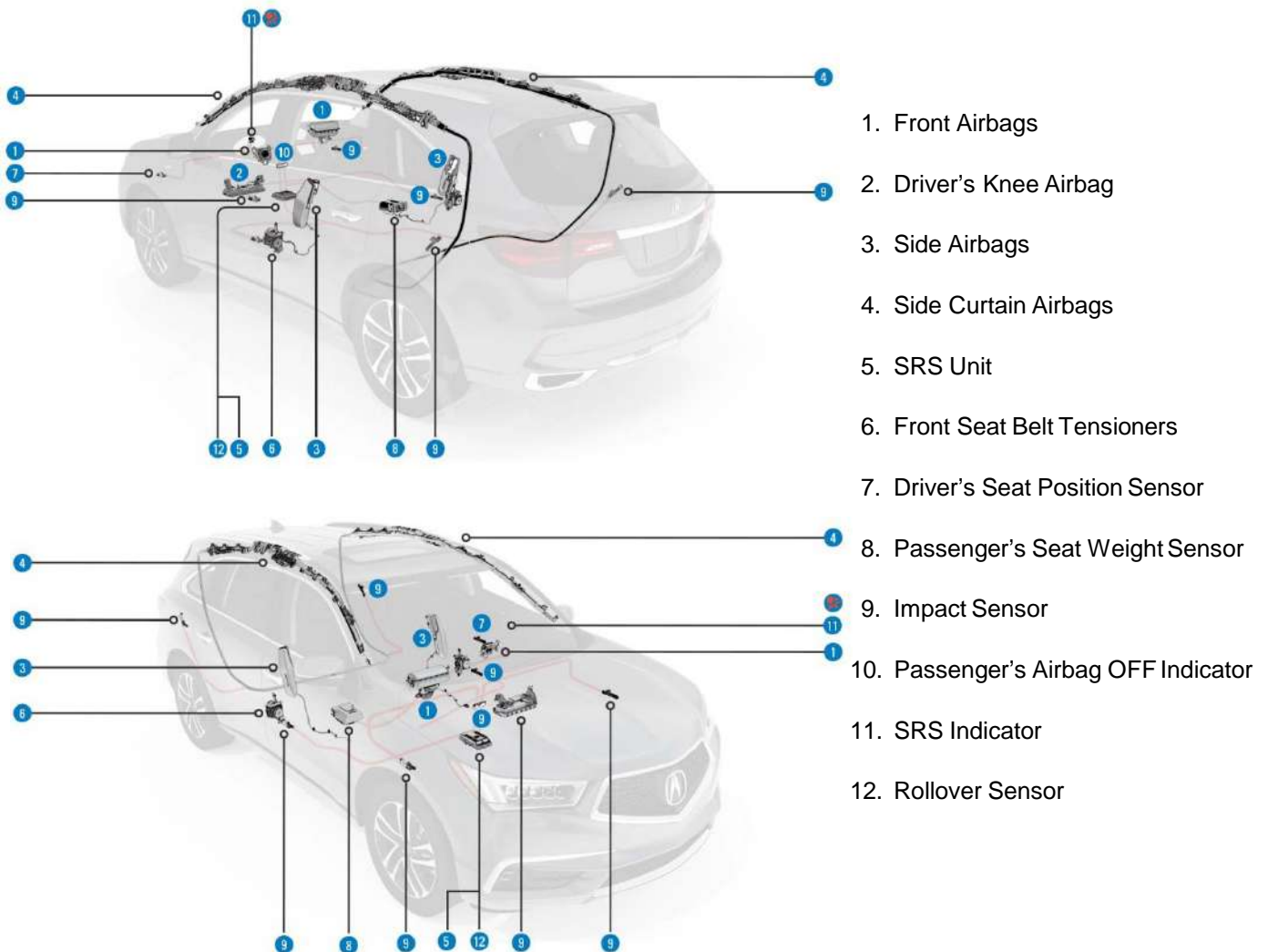

12-Volt Battery

A conventional 12-volt battery is located under the hood on the driver's side of the vehicle. This battery is used to start the engine and powers the airbags, lights, audio system, and other standard 12-volt system components. In an emergency situation, it may be necessary to disconnect or cut the 12-volt battery negative cable.

High-Voltage Battery

A 1.3 kilowatt hour (kWh) high-voltage lithium-ion battery pack is located in a well-protected area below the front seats. The battery pack is made up of 72 3.6-volt cells, totaling approximately 260 volts. The intelligent power unit (IPU) is housed with the battery pack and consists of the power control unit (PCU), the high-voltage battery ECU, the battery contactors, a forced air cooling system, and other battery system controls.

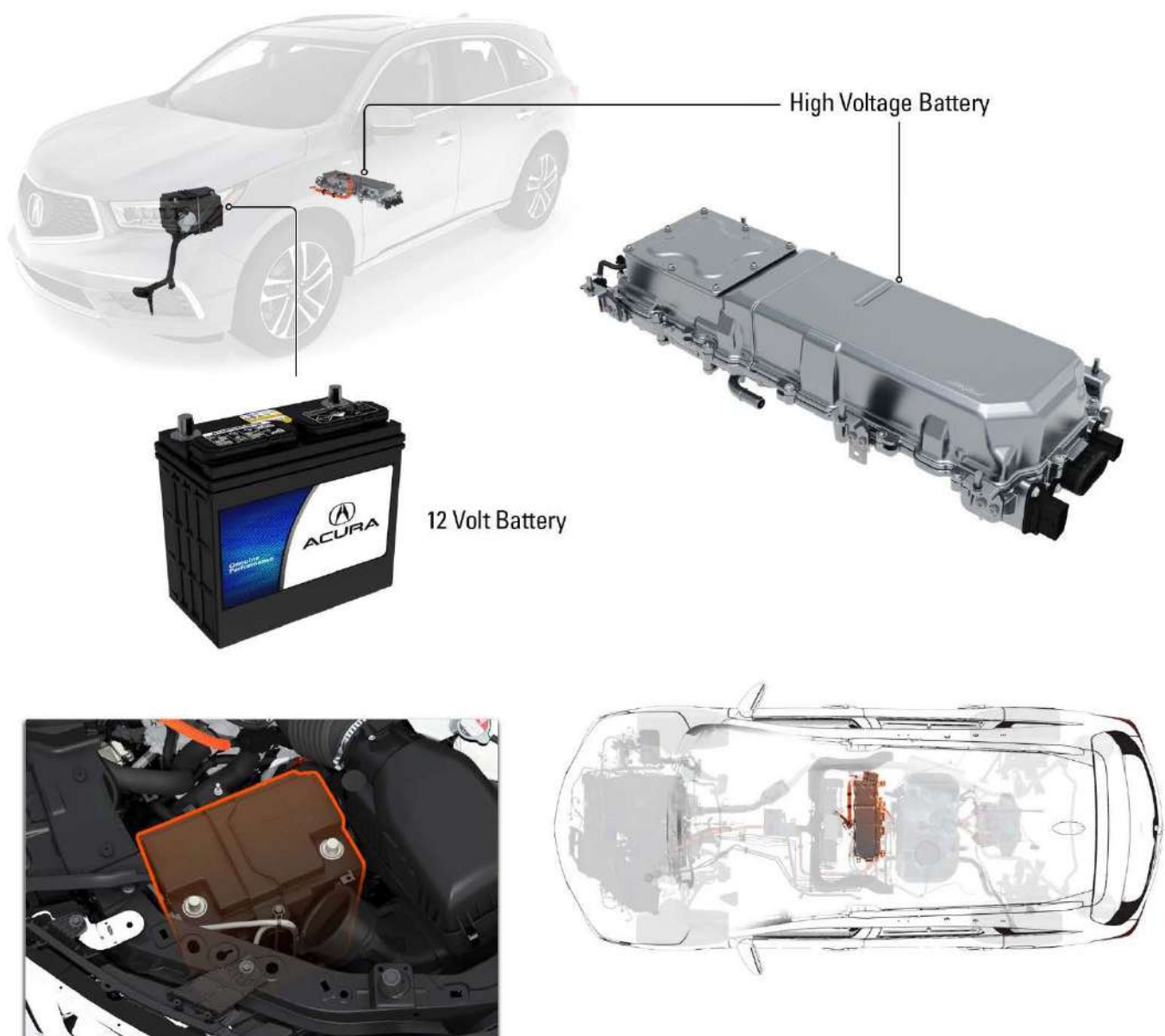

Key Components

Power Drive Unit (PDU)

The PDU is located below the center console and houses the liquid-cooled inverter and other high-voltage system components. There are no serviceable parts inside, so there is no reason for it to be opened or disassembled.

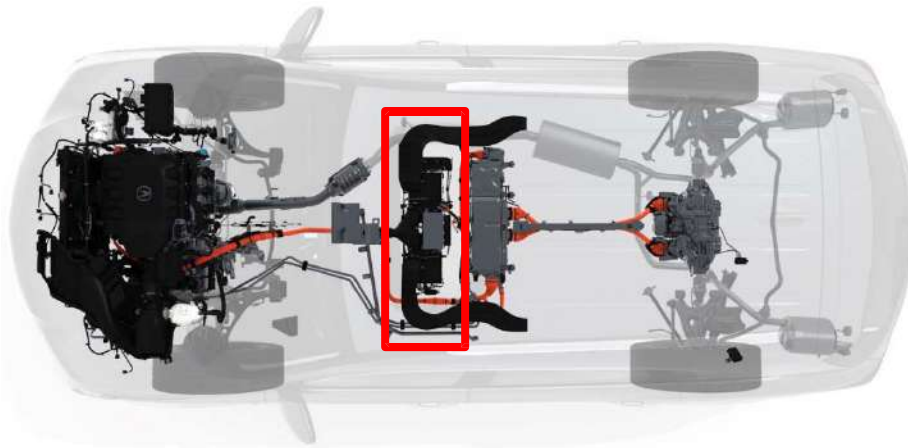

High-Voltage Cables

High voltage flows through easy-to-identify, heavy-duty orange cables. These cables are purposely routed through areas away from the usual cut points.



Electric Motor/Generator

The Acura MDX Sport Hybrid incorporates one electric motor/generator that is attached to the gasoline engine and transmission and two electric motors located between the rear wheels in the twin motor unit.



Key Components

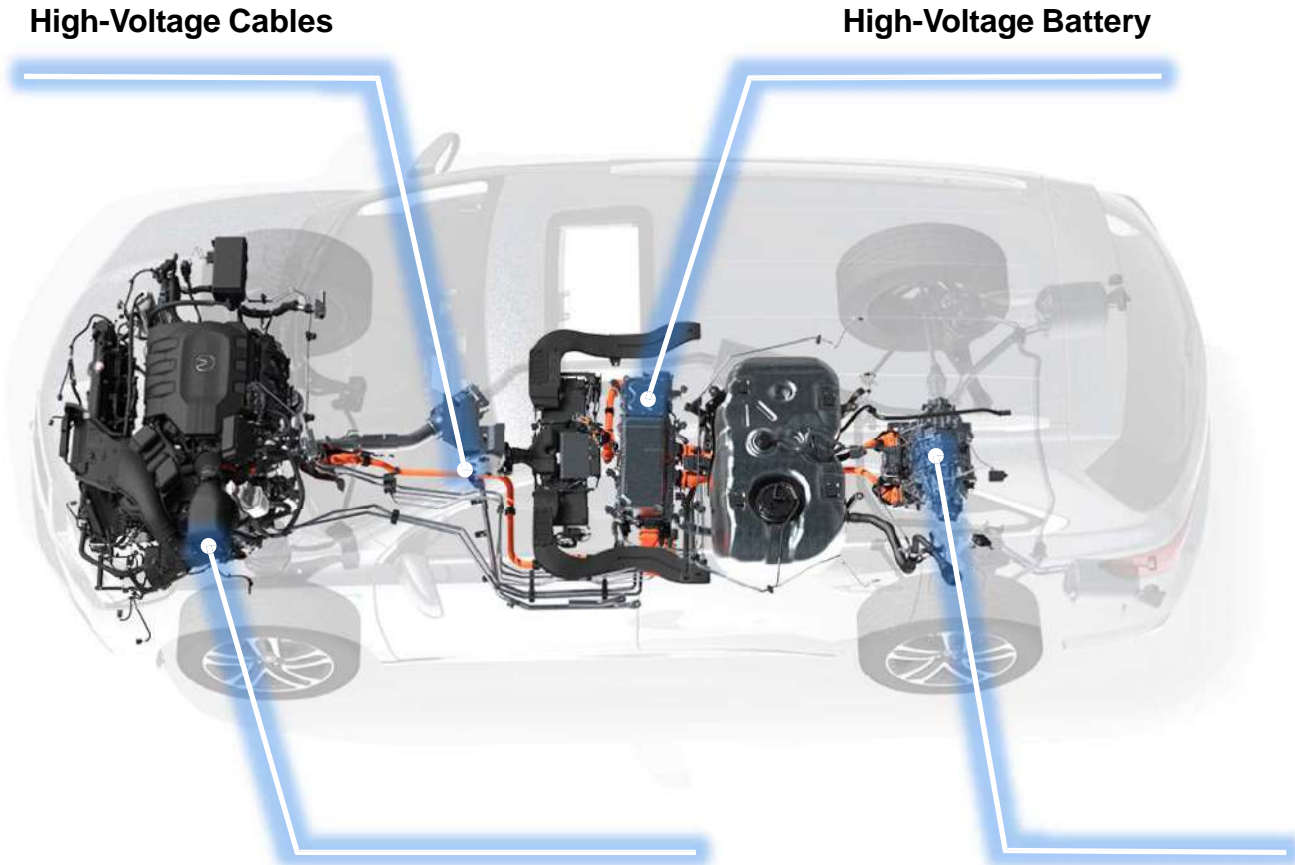

High-Voltage Cables

High-Voltage Battery

Front Electric Motor and Generator

Rear Electric Motors

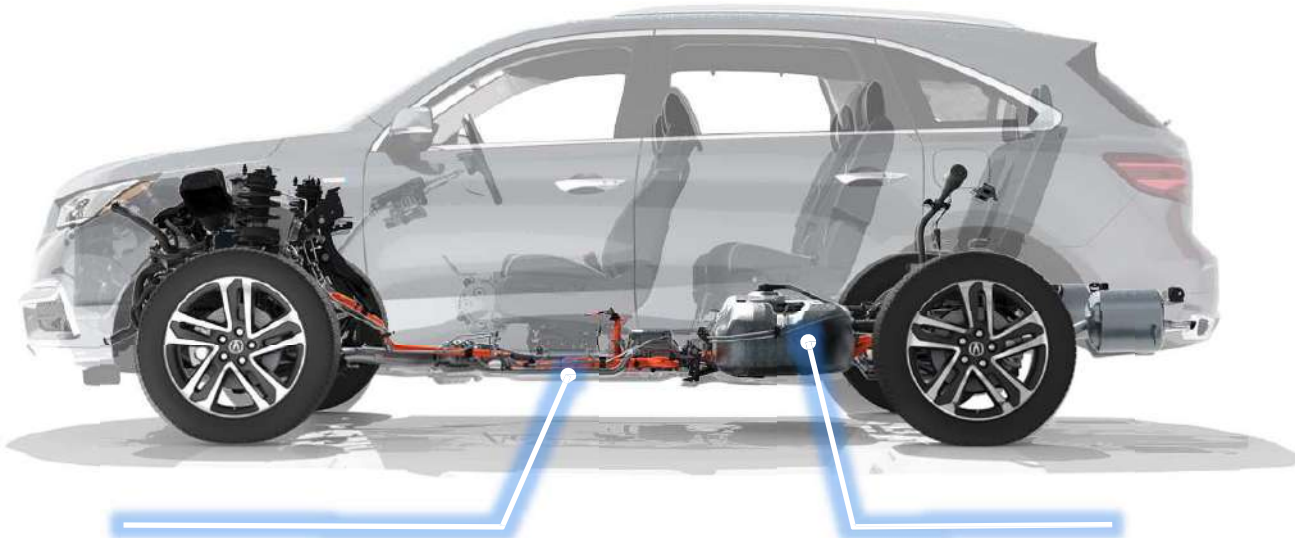

High-Voltage Cables

Fuel Tank

Key Components

High-Voltage A/C Compressor (under cover)

Fuse Box

Fuse Box

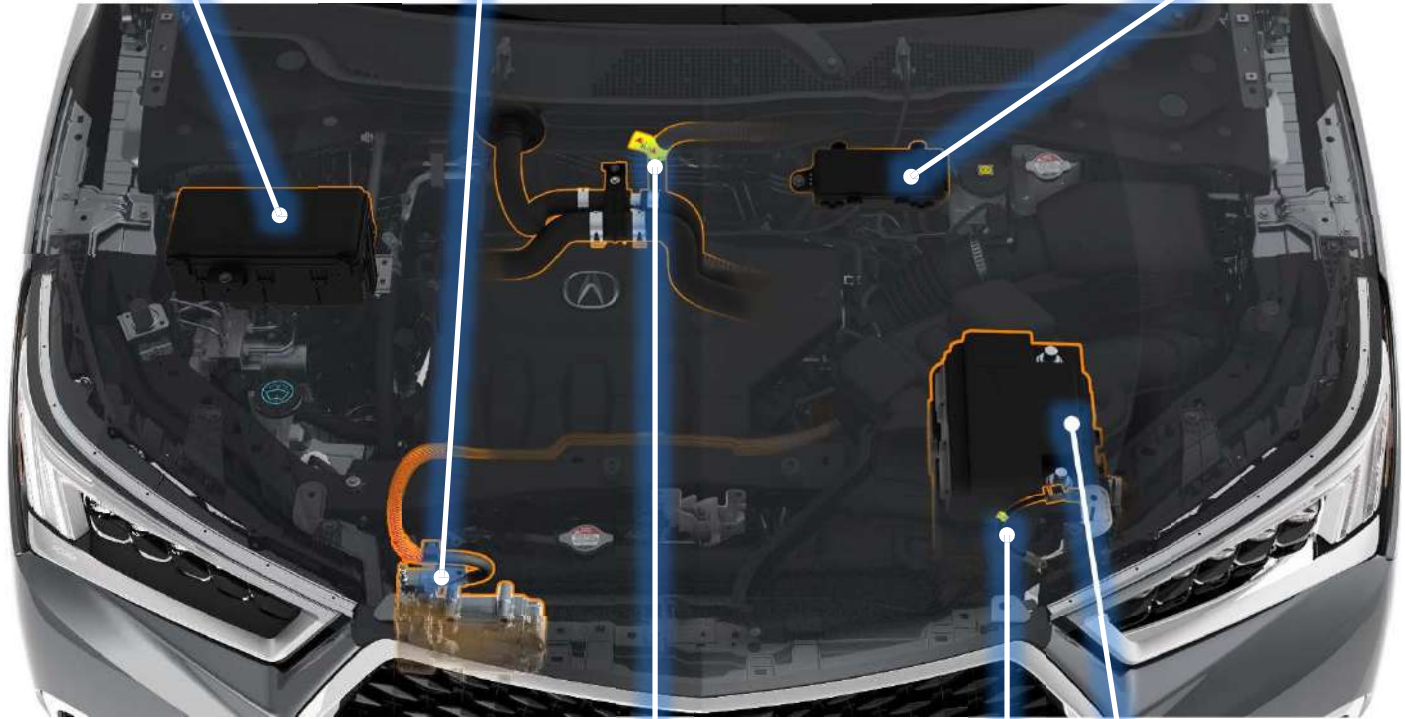

12-Volt Battery (under cover)



Cut x2

Cut Point Labels
(Refer to page 19 for more information.)

Lithium-ion Battery Fumes or Fire

A damaged high-voltage lithium-ion battery can emit toxic fumes. Also, the organic solvent used as electrolyte is flammable and corrosive. Responders should wear appropriate personal protective equipment. Even after a lithium-ion battery fire appears to have been extinguished, a renewed or delayed fire can occur. The battery manufacturer cautions responders that extinguishing a lithium-ion battery fire will take a large and sustained volume of water.

Responders should always ensure that an Acura MDX Sport Hybrid with a damaged battery is kept outdoors and far away from other flammable objects in order to minimize the possibility of collateral fire damage should the battery catch on fire.



Lithium-ion Battery Fluid

Avoid contact with the high-voltage battery fluid. The high-voltage battery contains a flammable electrolyte that could leak as a result of a severe crash. Avoid any skin or eye contact with the electrolyte as it is corrosive. If you accidentally touch it, flush your eyes or skin with a large quantity of water for at least 5 minutes and seek medical attention immediately.

Electric Shock

Unprotected contact with any electrically charged high-voltage component can cause serious injury or death. Receiving an electric shock from an Acura MDX Sport Hybrid, however, is highly unlikely because of the following:

- Contact with the battery module or other high-voltage components can only occur if they are damaged and the contents are exposed or if they are accessed without following proper precautions.
- Contact with the electric motor can only occur after one or more components are removed.
- The high-voltage cables can be easily identified by their distinctive orange color and contact with them can be avoided.

If severe damage causes high-voltage components to become exposed, responders should take appropriate precautions and wear appropriate insulated personal protective equipment.



Vehicle Collision

In the event of a crash, the SRS (Supplemental Restraint System) unit makes a judgment based on input from the impact sensors. If the input values meet various threshold requirements, the SRS unit sends a signal to the high-voltage battery ECU. The high-voltage battery ECU then turns off the high-voltage battery contactors, stopping the flow of electrical current from the high-voltage battery.

When responding to an incident involving an Acura MDX Sport Hybrid, we recommend that emergency personnel follow their organization's standard operating procedures for assessing and dealing with vehicle emergencies.

Given our knowledge of the Acura MDX Sport Hybrid, we also recommend that responders follow the procedures on the following pages to avoid potentially lethal shock by high voltage.



Submerged Vehicle

If an Acura MDX Sport Hybrid is submerged or partly submerged in water, first pull the vehicle out of the water. Then, shut down the high-voltage system using one of the two procedures described on the following pages.

Aside from severe damage to the vehicle, there is no risk of electric shock from touching the vehicle's body or framework — in or out of the water. If the high-voltage battery was submerged, you may hear noises from the battery as the cells are being discharged from shorting.



Preventing Current Flow Through High-Voltage Cables

Before attempting to rescue occupants or move a damaged Acura MDX Sport Hybrid, you should reduce the potential for current to flow from the electric motor or the high-voltage battery through the high-voltage cables.

There are *two recommended methods* for preventing current flow. These are discussed on the following pages.

BEST METHOD for High-Voltage Shutdown

Push and hold the POWER button for 2 seconds.

This simple action turns off the gasoline engine and immediately shuts down the high-voltage system controllers, thereby preventing current flow into the cables. It also cuts power to the airbags and the seat belt tensioners, though these pyrotechnic devices have up to a 3-minute deactivation time.

To prevent accidental restarting, you must remove the keyless remote from the vehicle and move it at least 20 feet away.

If you cannot locate the keyless remote, you should also do the SECOND-BEST METHOD for high-voltage shutdown (for preventing high-voltage current flow) on the following page.

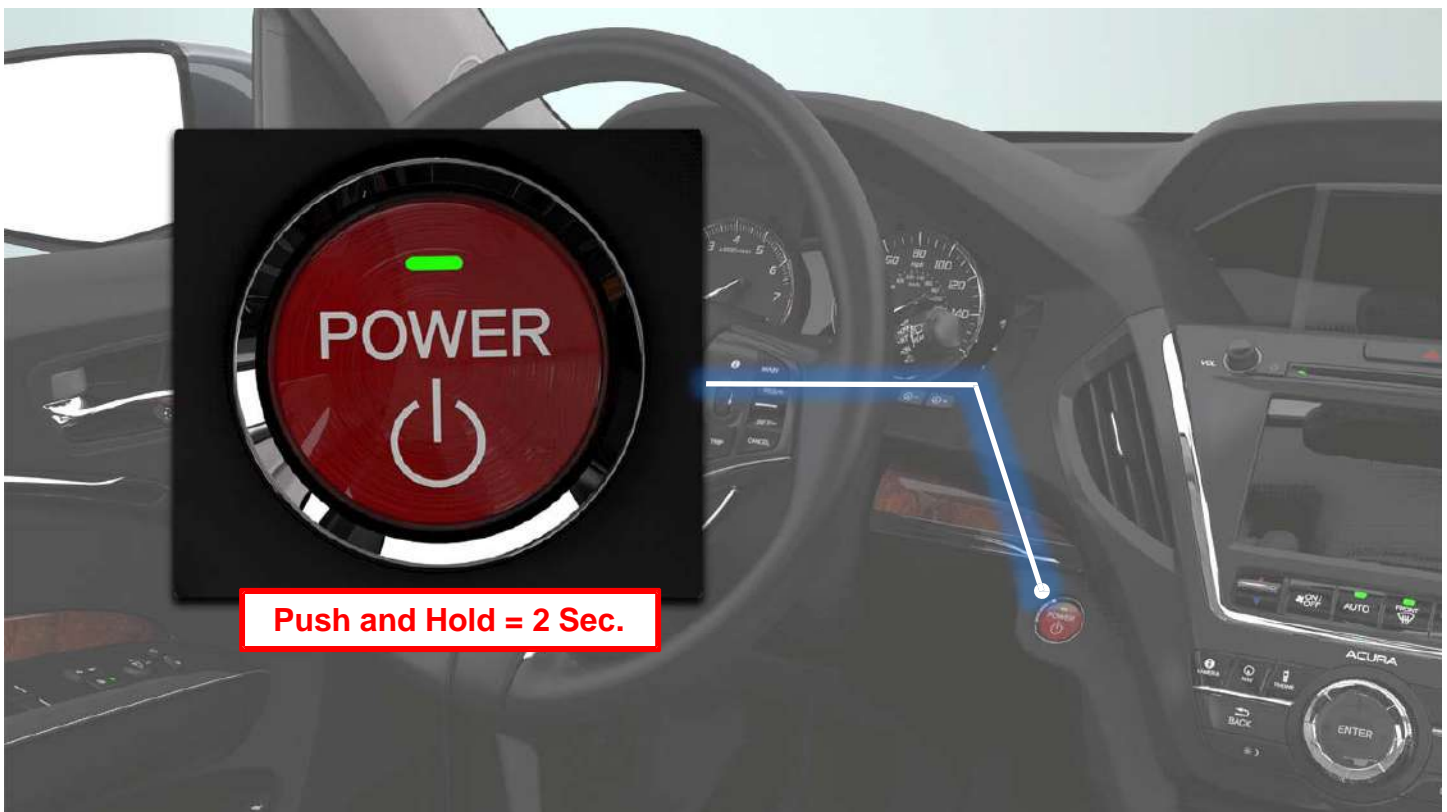

SECOND-BEST METHOD for High-Voltage Shutdown

Locate and cut the negative 12-volt battery cable and the DC-to-DC converter cable.

Together, cutting the negative 12-volt battery cable and cutting the DC-to-DC converter cable turns off the gasoline engine and immediately shuts down the high-voltage system controllers, thereby preventing current flow into the high-voltage cables.

1. Pull the hood release handle located on the driver's left kick panel.



2. Locate the hood latch lever, push the lever, and lift the hood.



SECOND-BEST METHOD for High-Voltage Shutdown

3. Locate the two cut point labels shown, and cut them.

When cutting the cables, do not allow the cutting tool to contact any surrounding metal parts; electrical arcing could occur, which can ignite any flammable vapors.

NOTE: If you cannot do either method to stop the engine and prevent current flow into the high-voltage cables, use extreme care and do not touch damaged cables as they may be electrically charged.

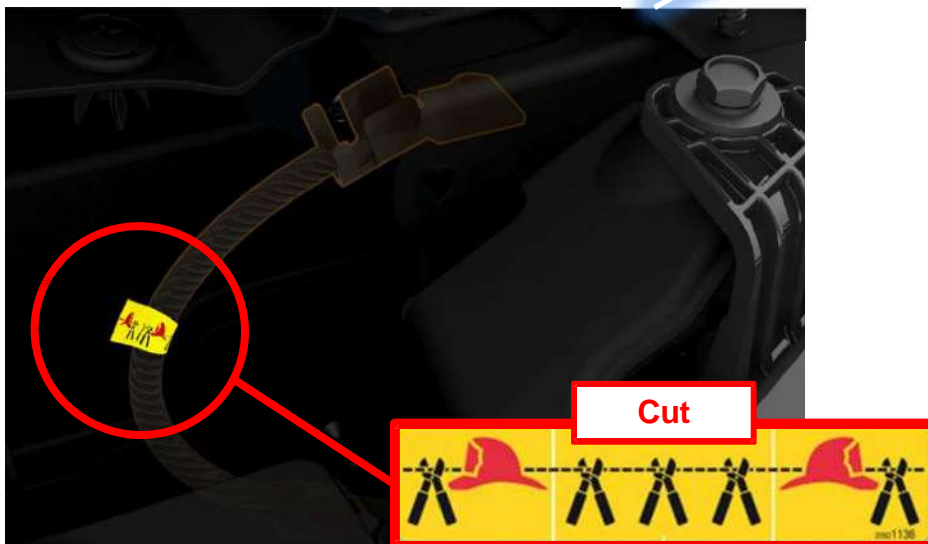

Extricating Occupants

If you need to cut the vehicle body or use Jaws-of-Life equipment to remove occupants, be sure to stay within the cut zone as shown below.



Emergency Towing

The only approved method is to use a flat-bed tow truck or trailer. Towing the vehicle with two wheels on the ground will damage parts of the electric powertrain system. If the vehicle is damaged, it must be transported on a flat-bed tow truck or trailer.

Be aware that when towing or rolling a damaged Acura MDX Sport Hybrid with the front and/or rear wheels on the ground, the electric motor can produce electricity and remains a potential source of electric shock even when the high-voltage system is turned off.

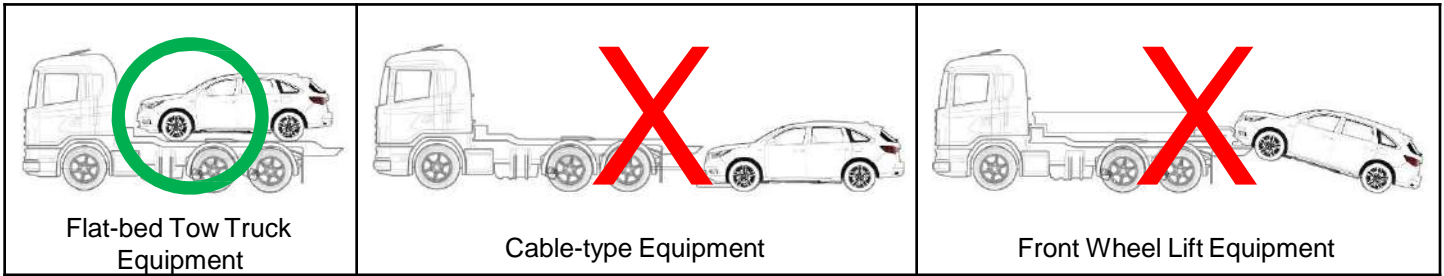

The tow hook is stored in the tool kit located in the rear cargo area. To install the tow hook, remove the cap from the rear bumper using a flat-tip screwdriver. Insert the tow hook, then turn it clockwise until it is snug.



Dealer Inspection and Repair

A damaged Acura MDX Sport Hybrid should be taken directly to an authorized Acura dealer for a thorough inspection and repairs. For questions, please contact your local Acura dealer or Acura Client Relations at 1-888-946-6329.

High-Voltage Battery Recycling

The high-voltage lithium-ion battery requires special handling and disposal. If disposal is necessary, please contact your local Acura dealer or the Canadian Transport Emergency Centre (CANUTEC) at 1 (888) 226-8832 for shipping instructions.

